

Cite this: *RSC Sustainability*, 2025, 3, 4955

Electrification in the chemical industry and its role in achieving carbon neutrality: areas, challenges, and opportunities for process intensification

Juan Gabriel Segovia-Hernández, *^a Jesús Manuel Núñez-López,^a Enrique Cossío-Vargas,^b Maricruz Juárez-García^a and Eduardo Sánchez-Ramírez^a

Electrification in the chemical industry is increasingly regarded as a key enabler of carbon neutrality. By substituting conventional fossil-based heat and power with electricity, particularly when sourced from low-carbon and renewable systems, the sector can significantly reduce greenhouse gas emissions while enhancing energy efficiency. However, the true impact on carbon neutrality strongly depends on the carbon intensity of the electricity supply, which requires parallel decarbonization of power generation systems. This article reviews the technological pathways, opportunities, and challenges of large-scale electrification in chemical processes, with emphasis on process integration, flexibility, and system-level interactions with evolving energy infrastructures. Moreover, it highlights the role of policy frameworks, market incentives, and cross-sectoral synergies in accelerating deployment. The discussion underscores that electrification, coupled with sustainable electricity generation, is central to achieving long-term climate goals and fostering an energy transition consistent with carbon neutrality.

Received 20th May 2025
Accepted 2nd September 2025

DOI: 10.1039/d5su00356c

rsc.li/rscsus

Sustainability spotlight

This article offers a comprehensive and forward-looking exploration of electrification as a transformative enabler of process intensification within the chemical industry, directly addressing the urgent global imperative to decarbonize industrial sectors and meet international climate goals. By systematically evaluating the integration of electrified technologies—ranging from electrochemical synthesis, plasma-assisted reactions, microwave and induction heating, to electrically driven membrane separations and heat pump-assisted distillation—the study demonstrates how electrification can substantially reduce the sector's dependency on fossil fuels, minimize energy consumption, and mitigate greenhouse gas emissions. The work is particularly relevant in the context of the United Nations Sustainable Development Goals (SDGs), particularly Goals 7 (Affordable and Clean Energy), 9 (Industry, Innovation and Infrastructure), 12 (Responsible Consumption and Production), and 13 (Climate Action). Through detailed technical analysis and case studies, the authors show how electrification not only enables modular, decentralized, and more controllable chemical processes, but also facilitates the direct coupling of renewable energy sources—such as wind, solar, and hydroelectric power—with industrial operations. This alignment enhances resource efficiency, process flexibility, and resilience in the face of fluctuating energy markets and climate regulations. Beyond technological innovation, the article delves into the socio-technical and policy dimensions of the electrification transition. It emphasizes the necessity of rethinking current infrastructure, retraining the workforce, updating regulatory frameworks, and fostering multi-stakeholder collaboration to accelerate the adoption of electrified systems. The authors propose strategic approaches to overcome barriers related to scalability, economic viability, and integration with existing operations, calling for a systemic shift supported by digitalization, artificial intelligence, and energy storage technologies. Ultimately, this article contributes to the growing body of literature advocating for electrification as a cornerstone of industrial sustainability. It underscores that electrification is not merely a technical upgrade but a paradigm shift that redefines how chemicals are produced, with far-reaching implications for carbon neutrality, circular economy implementation, and long-term environmental stewardship. The research reinforces the urgency and feasibility of transitioning toward a clean, electrified, and intensified chemical industry as a critical pathway to achieving a just and sustainable future.

1. Introduction

One of the most promising pathways to decarbonize the chemical industry is through electrification. This process involves substituting fossil fuel-based energy sources with

electricity, ideally generated from renewable sources such as wind, solar, or hydroelectric power. However, the global electricity mix is still dominated by fossil fuels, which in 2023 accounted for approximately 61% of total electricity generation (coal 35%, natural gas 23%, oil 3%), while renewables—including hydro, wind, solar, and biomass—supplied about 30%, and nuclear around 9%.¹ These figures highlight that the decarbonization potential of electrification depends directly on the extent to which renewable energy is integrated into national and regional power grids. Consequently, electrification represents not just a change in energy sources but a fundamental

^aUniversidad de Guanajuato, División de Ciencias Naturales y Exactas, Departamento de Ingeniería Química, Campus Guanajuato, Noria Alta s/n, 36050, Guanajuato, Gto, Mexico. E-mail: gsegovia@ugto.mx

^bUniversidad Tecnológica del Suroeste de Guanajuato, Carr. Valle-Huanimaro km 1.2, Valle de Santiago, Guanajuato, 38400, Mexico



shift in how chemical processes are designed and executed, provided it is accompanied by systemic efforts to accelerate the deployment of low-carbon electricity. Process Intensification (PI) is particularly relevant in this context, as it aims to achieve the same or better chemical output using fewer resources and with less environmental impact. One of the most promising pathways to decarbonize the chemical industry is through electrification. This process involves substituting fossil fuel-based energy sources with electricity, ideally generated from renewable sources such as wind, solar, or hydroelectric power. Electrification represents not just a change in energy sources but a fundamental shift in how chemical processes are designed and executed.² Process Intensification is particularly relevant in the context of electrification as it aims to achieve the same or better chemical output using fewer resources and with less environmental impact.

By integrating electrification with Process Intensification (PI) principles, the chemical industry can achieve substantial gains in energy efficiency, process safety, and operational flexibility.³ Electrification not only enables precise thermal control and rapid dynamic response but also facilitates the replacement of fossil-based utilities with renewable electricity, directly contributing to carbon neutrality targets. These attributes make electrification a critical enabler for low-carbon manufacturing pathways.⁴

At the same time, the synergies between electrification and PI open opportunities for innovative process designs that reduce equipment size, minimize thermal losses, and enhance product selectivity. Sectors such as petrochemicals, fine chemicals, and separations stand to benefit significantly from these advances, particularly when coupled with renewable power integration and digital optimization tools. As a result, electrification must be viewed not merely as a substitution of energy sources but as a transformative strategy to redesign industrial processes for a sustainable future.⁵

Despite these promising opportunities, several challenges must be addressed to fully realize the benefits of electrification in the chemical industry. These challenges include the high capital costs associated with the implementation of new technologies. The initial investment required for electrification technologies can be prohibitive, particularly for small and medium-sized enterprises (SMEs) within the chemical sector. Additionally, the transition may necessitate significant modifications to existing infrastructure, leading to potential operational disruptions during implementation. The need for skilled workforce development, the potential risks of technological integration during the transition, the availability and stability of renewable energy sources may also influence the feasibility of electrification initiatives, are other important challenges such as the necessity of adaptation of existing regulatory frameworks and market structures to incentivize and support electrification efforts.

The purpose of this paper is to critically examine the specific areas within the chemical industry where electrification can effectively drive process intensification while identifying the associated challenges and opportunities. This paper aims to provide a thorough analysis of the role of electrification in the

chemical industry, highlighting both the challenges and opportunities that lie ahead during this critical transition,⁶ thus presenting a roadmap for its effective implementation in the chemical industry. By identifying the synergies between electrification and process intensification, this research aims to catalyze a paradigm shift towards a more sustainable chemical industry capable of meeting the demands of a rapidly changing global environment.

To guide this investigation, several key research questions are posed:

(a) What are the most promising technologies and processes for electrification in the chemical industry?

(b) How can electrification enhance process efficiency and reduce emissions?

(c) What are the primary barriers to implementing electrification in this sector?

(d) What potential advantages can be realized through the widespread adoption of electrification?

These questions form the foundation of the research focus, directing attention to the critical areas within the chemical industry that are ripe for electrification and identifying the barriers that may hinder progress.

2. Key areas for process intensification through electrification in the chemical industry

This section addresses the most promising technologies and processes within the chemical industry to be electrified. It covers how these electrification technologies have been successfully implemented and how their use can be extended into three important aspects of the overall process: heating, reaction and separation.

2.1 Thermal process intensification

One keyway to improving process intensification (PI) lies in the replacement of traditional fossil-fuel-based heat sources with electric heating technologies. The chemical industry has long relied on conventional methods, like steam and gas heating systems, which also emit significant greenhouse gas emissions. Therefore, developing new electric-heating strategies such as electric furnaces, microwave heating, microwave-assisted heating and induction heating, is essential. Electric furnaces are particularly impactful because they offer precise temperature control, improving reaction conditions and product quality while reducing energy waste. This makes them more sustainable than fossil fuels and allows for lower emissions, supporting global sustainability goals.⁷

Induction heating (HI), which utilizes electromagnetic fields to generate heat directly within the material. This technology enables rapid heating and minimizes heat loss to the surroundings, resulting in improved thermal efficiency, especially in processes requiring high temperatures, such as metal processing and certain catalytic reactions. By enhancing the kinetics of these reactions, induction heating can lead to



shorter processing times, reduced energy consumption, and increased overall yield.

Microwave-assisted heating selectively heats materials using microwave radiation, offering fast heating and better energy utilization. This is particularly useful in heterogeneous reactions, where different materials heat at different rates. This method reduces the time and energy required, lowers emissions, and helps design smaller, more efficient chemical reactors, especially for modular plants. Nowadays, electric furnaces are used for melting metals, like in the aluminium industry, have a 90% efficiency rate compared to only 23 to 27.5% for fuel furnaces and 50 to 70% of the heat is lost with the exhaust gases.⁸

Microwave heating, originally used in food processing, is now applied in polymerization, green chemistry, and ceramics, offering benefits like reproducibility and safety. Electric heating methods offer easy temperature control, quick shutdowns for safety, and broader sustainability benefits. They can lower operational costs, especially in areas with renewable energy sources, and help the chemical industry transition to a low-carbon economy. Additionally, electric heating reduces reliance on volatile fossil fuel markets, offering greater stability in energy costs. However, the initial investment in electric heating systems can be high, and modifying existing plants to integrate these technologies requires careful planning. A reliable, sustainable electricity supply is also critical. To maximize electrification's benefits, the availability of low-carbon electricity sources, like solar or wind, is essential.⁹

To provide a clearer perspective on the practical advantages and limitations of different electric heating technologies, Table 1 summarizes quantitative data regarding typical and best-case efficiency, operating ranges, representative industrial applications, and indicative operating cost reductions enabled by electrification. Compared to conventional fossil-fuel-based furnaces, electric systems consistently demonstrate higher energy efficiency, faster response times, and improved controllability. For instance, electric resistance furnaces typically reach 85–95% efficiency, whereas fuel-fired furnaces seldom exceed 30%. Microwave and induction heating offer not only high thermal efficiencies but also enhanced selectivity, enabling rapid heating of target materials while minimizing bulk energy losses. The data confirm that the choice of electric heating technology depends strongly on process requirements. Electric furnaces are well suited for large-scale, high-temperature operations such as metal smelting, while induction heating is particularly advantageous in catalytic or metallurgical processes requiring localized heating and minimal thermal inertia. Conversely, microwave heating excels in heterogeneous and modular processes, where selective heating can reduce overall energy consumption and facilitate compact reactor designs. Plasma heating, while less efficient in energy conversion, enables extremely high temperatures and highly reactive environments, making it valuable for advanced reforming and materials synthesis. Beyond technical performance, the cost dimension is also critical. As shown in Table 1, electrification can deliver potential OPEX reductions in the range of 10–30% under favourable conditions, particularly

Table 1 Comparative performance and cost impact of conventional vs. electric heating^{7–9,13,53}

Technology	Typical efficiency (%)	Best-case efficiency with PI & heat recovery (%)	Operating temperature range (°C)	Heating characteristics	Representative applications	Potential OPEX reduction via electrification ^a (%)
Fuel-fired furnace	20–35	35–45	Up to 1800	Indirect heating; notable flue-gas and standby losses	Glass production, cement kilns, conventional metallurgy	— (baseline)
Electric resistance furnace	85–95	95–99	Up to 2000	Uniform bulk heating; precise temperature control	Metal melting (Al, steel), ceramics	10–25
Induction heating	70–90	85–95	Up to 1600	Direct volumetric/localized heating; very fast thermal response	Catalytic tubes, metallurgical processing, specialty alloys	15–30
Microwave heating	60–85	75–90	Up to ~1000	Selective volumetric heating; strong in polar/heterogeneous media	Organic synthesis, polymer curing, ceramic sintering, modular units	10–25
Plasma heating	50–70 (process-dependent)	60–80	>2000	Extremely high energy density; reactive environments	Plasma gasification, advanced reforming, high-value materials	0–15

^a Assumptions for “Potential Optimizing Operating Expenses (OPEX) Reduction”: favorable scenarios with (i) delivered electricity ≤ 30 –40 USD per MWh (e.g., renewable PPA), (ii) explicit carbon cost ≥ 50 –100 USD per t CO₂ or equivalent constraint, and (iii) maintenance savings from electrified heat islands (e.g., reduced combustion air handling, flue-gas treatment). Ranges reflect process duty, load factor, and site integration; actual outcomes may be lower or negative if electricity prices are high or carbon constraints are weak.



when low-cost renewable electricity and carbon pricing mechanisms are available. These distinctions highlight that electrification is not a one-size-fits-all solution but must be carefully aligned with process intensification strategies, local energy prices, and policy frameworks to maximize both energy efficiency and economic benefits while reducing emissions.

2.2 Notes on interpretation

- Efficiencies are thermal/energetic conversion at the point of use and exclude upstream generation/transmissions effects.
 - “Best-case efficiency” reflects optimized controls, heat recovery, and PI aligned equipment sizing (*e.g.* compact reactors, minimized thermal inertia).
 - Where electrification enables tighter temperature profiles and faster ramping, additional indirect savings (quality yield, shorter cycle times) may accrue but are not included in the OPEX range.

2.3 Electrification of reaction engineering

Electrification is also transforming reaction engineering, through electrochemical processes, which use electricity to drive chemical reactions. These processes typically operate under milder conditions, offering better reaction control, improving selectivity and reduced byproduct formation than traditional thermal methods.

One prominent example is the electrochemical synthesis of valuable chemicals, such as organic acids, alcohols, and other fine chemicals. These synthesis routes can achieve high conversion rates with significantly lower energy inputs compared to conventional methods. The incorporation of electrocatalysts is critical in this context, as these specialized materials enhance the selectivity of electrochemical processes. These catalysts optimize the reaction pathways, boosting process efficiency and sustainability. Electrochemical processes allow for tailored synthesis, which is useful in industries like pharmaceuticals where product specifications can vary. A good example is the electrochemical oxidation of glycerol, which operates at room temperature and offers better selectivity than traditional methods.¹⁰

By utilizing renewable energy, such as solar, wind, or hydroelectric power, the chemical industry can produce essential chemicals with substantially lower carbon footprints. This shift supports the transition to a circular economy, where waste is minimized, and resources are efficiently used.¹¹ Power-to-X technologies, which convert renewable electricity into various chemical forms, such as hydrogen or syngas, further enable sustainable production.

Electrochemical methods also help tackle carbon dioxide (CO₂) emissions by converting CO₂ into valuable products like methanol or formic acid, closing the carbon loop and helping meet climate goals. However, developing efficient electrocatalysts is essential, as current materials may not be deal for industrial applications. Additionally, scaling electrochemical processes from the lab to commercial scale requires careful planning and consideration of reactor design, system integration, and cost-effectiveness. The high cost of new technology

could determine some industries, highlighting the need for supportive and research investment.

2.4 Separation processes

Separation processes rank among the most energy-intensive operations within the chemical industry, making them ideal candidates for electrification and process intensification. Conventional separation methods, such as distillation and absorption, often require significant thermal energy inputs, leading to high operational costs and considerable greenhouse gas emissions. Electrification can improve these processes by enhancing energy efficiency and reducing environmental impacts, particularly in membrane-based systems and electrically driven separations.¹²

Techniques such as electrofiltration and electrodialysis offer innovative, energy-efficient solutions. In electrofiltration, an electric field is applied across a membrane, facilitating the selective transport of charged particles while retaining larger molecules or impurities. This method not only increases the separation efficiency but also reduces the need for extensive pre-treatment steps, thereby streamlining the overall process. Similarly, electrodialysis utilizes ion-selective membranes and an electric field, which is particularly useful for separating salts and ions in applications like water desalination and wastewater treatment. Electro-assisted distillation, which applies electrical energy to enhance vapor–liquid interactions, reduces the energy needed for separation, especially for azeotropic mixtures or substances with close boiling points.

However, challenges include developing durable membranes and materials that can handle the conditions of electricity driven processes. Scalability is also a concern, as laboratory successes must be translated into large-scale operations. The high initial costs and need for new infrastructure may deter some companies, but supportive policies and investment in research are crucial for growth.

3. Advances and development of the chemical industry by process intensification through electrification

This section provides an in-depth analysis of five key areas where electrification can unlock significant advancements: electrically driven reaction pathways, reduction of process steps, process control and optimization, and synergies with digitalization and artificial intelligence (AI).

3.1 Electrically driven reaction pathways

By using renewable electricity, it is possible to move towards processes with very low net emissions, often described as “carbon-neutral”. However, it is important to recognize that even renewable energy systems involve carbon inputs during their fabrication, installation, and maintenance, meaning that absolute neutrality is rarely achieved.¹³ Instead, the aim is to minimize lifecycle emissions to the greatest possible extent, achieving near-carbon-neutral or net-zero pathways. In this



context, electrification powered by renewables provides a substantial reduction in greenhouse gas emissions compared to fossil-based alternatives and represents one of the most effective routes for aligning chemical production with long-term climate targets.

3.1.1 Electrochemical pathways. Electrochemical processes use direct electron transfer to facilitate reactions without the need for extreme temperatures or pressures. This allows precise control over reaction speed and selectivity, making reactions more efficient. For example, in carbon dioxide reduction, electrochemical methods can convert CO₂ into useful chemicals like formic acid or methanol with less energy. Similarly, electrochemical oxidation can selectively modify organic molecules, supporting the production of pharmaceuticals and fine chemicals.¹⁴ Additionally, these processes can be integrated with renewable energy sources such as solar or wind, further enhancing their sustainability. By using renewable electricity, it is possible to create fully carbon-neutral processes that are both economically viable and environmentally friendly.

3.1.2 Plasma technologies and non-thermal reactions. Plasma technologies use ionized gases to create highly reactive environments that allow chemical reactions at low temperatures but with the energy density of high-temperature processes. Plasma processes can achieve high conversion rates with less energy than traditional methods. For example, plasma-assisted ammonia synthesis eliminates the need for high temperatures and pressures, making it more energy-efficient and cost-effective. Plasma can also be used in hydrocarbon cracking and reforming, where it offers a more energy-efficient alternative to traditional methods, reducing both energy consumption and emissions.

Electrically driven reaction pathways, made possible through electrochemical and plasma technologies, provide excitement to improve the efficiency and sustainability of chemical processes. One of the most exciting opportunities for electrically driven reaction pathways is in carbon dioxide (CO₂) utilization. As global industries seek to reduce their carbon footprints, CO₂ conversion technologies have gained significant attention to recycling CO₂ into valuable products. Both electrochemical and plasma-based methods offer promising routes for CO₂ activation and conversion, presenting a viable path towards carbon-neutral or even carbon-negative processes.¹⁵ In electrochemical CO₂ reduction, electrical energy is used to convert CO₂ into a variety of carbon-based products, such as methanol, ethanol, or even synthetic fuels, addressing emissions and creating closed-loop systems. By adjusting voltage and current, this process can be tailored to produce different compounds. Plasma-based CO₂ conversion also operates at lower pressures and temperatures, making it an efficient and scalable method for CO₂ reduction. The combination of plasma with catalytic surfaces can enhance reaction rates and selectivity, making this approach a promising candidate for large-scale CO₂ utilization.

Electrochemical and plasma-based technologies can be tailored to specific process requirements, enabling smaller, modular production units.¹⁶ This shift toward modular, electrified systems aligns with the growing trend of distributed manufacturing, where production facilities are located closer to

raw material sources or end users, reducing transportation costs and emissions.

3.2 Reduction of process steps

Conventional chemical processes often involve several energy-intensive steps, such as heating, cooling, pressurizing, and separating various chemical species. Electrochemical systems allow the intensification of processes by combining different reaction and separation steps in a single operation, cutting down on equipment needs and energy use,¹⁷ thus simplifying traditionally complex chemical processes, offering a transformative shift in how chemical reactions and separations are performed. For example, electrochemical cells can perform oxidation and reduction reactions simultaneously, eliminating the need for separate stages like heating or pressurization,¹⁸ or water electrolysis for hydrogen production, where hydrogen and oxygen are separated within the same electrochemical cell.

This integration reduces the footprint of the process, and the amount of supporting equipment needed, such as heat exchangers, compressors, and distillation columns, leading to significant savings in both capital and operational costs. Electrification can reduce the need for energy-demanding separations processes like distillation by facilitating more selective reactions. As mentioned above, electrochemical systems drive selective reactions, producing fewer by-products, therefore requiring less post-reaction purification.¹⁹

Electrification additionally enables modular and distributed production systems. These systems offer compact and flexible units that can be near raw material sources or end users. This has multiple benefits, including reduced transportation costs and carbon emissions associated with the process. In addition, electrification can promote flexibility in production systems, allowing rapid adaptation to demand changes. This adaptability is particularly beneficial in remote or resource-constrained areas.²⁰ This greater control in production planning inherently leads to a reduction in waste generation and energy use, allowing cost savings, and with the inclusion of the use of renewable energies, supports decarbonization.²¹ Additionally, the integration of operations into fewer steps through electrification enhances production speed by eliminating traditional bottlenecks, resulting in higher throughput and shorter cycle times, especially beneficial in time-sensitive industries like pharmaceuticals.²²

3.3 Process control and optimization

Another fundamental advantage of electrification in process intensification is the ability to precisely control and optimize reaction conditions with a level of precision that overcomes conventional methods. Electrically driven technologies, such as electrochemical reactors and plasma systems, offer real-time, highly tuneable control over key reaction parameters, including reaction kinetics, temperature profiles, and mass transfer rates. Similarly, the heating systems allow for more efficient control of heating and temperature profiles and energy use. This level of control is difficult to achieve with conventional thermal methods, which rely on heating and suffer from inefficiencies.²³



3.3.1 Real-time adjustment of reaction kinetics. One of the most significant advantages of electrochemical reactors is their capacity for real-time manipulation of reaction kinetics. In traditional thermal reactors, adjusting reaction rates requires changes to bulk parameters such as temperature or pressure, often leading to slow response times and inefficiencies. In contrast, electrochemical reactors allow for the direct modulation of reaction rates by adjusting the applied voltage or current. This offers immediate control over electron transfer processes, enabling operators to fine-tune the reaction rates as needed for specific process requirements. This is particularly attractive in multi-step reactions, for example, in producing fine chemicals or pharmaceuticals, adjusting reaction rates quickly improve product yields and reduce side reactions.²⁴

3.3.2 Precision in temperature control and profile management. Besides, electrified processes allow for precise temperature control within the reactor, unlike traditional systems that struggle with even heating. This is especially useful for reactions sensitive to temperature changes. It helps prevent thermal degradation of sensitive reactants and ensures reactions occur under optimal conditions, improving yields and reducing energy use.²⁵

3.3.3 Enhanced mass transfer and electromagnetic control. In electrochemical processes, the movement of ions and electrons can be precisely directed, improving the efficiency of reactant transport to the reaction site. This level of control is especially beneficial in reactions that are diffusion-limited, where improving mass transfer rates can significantly enhance reaction kinetics and overall process efficiency.²⁶ Plasma technologies, which rely on electromagnetic fields to generate highly reactive species, offer another avenue for improving mass transfer in chemical reactions. Plasma-induced reactions typically occur at the gas–liquid or gas–solid interfaces, allowing for enhanced interaction between reactants and active sites. This results in faster reaction rates and higher product yields compared to conventional processes, where mass transfer limitations often hinder reaction efficiency. Electromagnetic fields can also be used in catalytic processes to improve catalyst activity and selectivity, which is useful for converting renewable resources like biomass or CO₂.²⁷

Electrochemical and plasma technologies can work under non-equilibrium conditions, allowing for the development of more efficient processes with lower energy use.²⁸ For example, electrochemical methods can convert biomass into valuable chemicals, while plasma technologies enable selective reactions at low temperatures, offering potential for energy-efficient processes in ammonia synthesis, methane reforming, and CO₂ utilization.²⁹

The real-time control capabilities of electrically driven systems provide an ideal platform for implementing predictive models and optimization algorithms that can continuously monitor and adjust reaction parameters to maximize efficiency and minimize waste.³⁰ This integration led to smarter, more flexible systems that can adapt to changing conditions, moving towards fully automated, optimized processes as part of Industry 4.0.³¹

3.4 Synergies with digitalization and AI

Integrating electrification with digitalization and artificial intelligence (AI) offers significant benefits for the chemical industry, ushering in an era of real-time process optimization that was previously not possible. In this context, electrified processes can generate large amounts of real-time data, which AI algorithms can analyze to identify patterns and models that would optimize process performance. For example, in an electrochemical reactor, AI tools can predict the optimal voltage or current needed to obtain maximum product selectivity and energy efficiency. On the other hand, these models can also detect inefficiencies and correct them in real time, allowing continuous improvements in multi-step processes.³²

In this sense a very interesting concept of the digitalization era arises, the “digital twins”, which are a virtual representation of a process or system. This works as a “digital clone” that simulates, analyzes and predicts the behaviour of its physical counterpart, allowing in this case a continuous monitoring of the processes in real time. They also allow risk-free testing of changes to the real process. A digital twin of an electrified separation process can simulate the impact of changing electrical fields, helping operators make informed decisions to optimize efficiency and reduce errors or downtime, AI and machine learning can further automate this process, adjusting conditions based on real-time.³³

AI driven optimization can identify the most energy-efficient settings in real time and reduce waste by ensuring processes operate at peak efficiency. For example, in an electrified reactor, AI can monitor and adjust conditions to prevent unwanted byproducts, cutting down on the need for additional purification and reducing environmental harm.³⁴ Furthermore, probably one of the greatest advantages offered by the electrification of the chemical industry is the possibility of electrified processes to be synchronized with smart grids, which has been a major challenge in conventional industry and has greatly limited the use of renewable energies in large-scale power systems due to the fluctuations in their availability. AI-controlled systems can manage these fluctuations and optimize operations contributing to sustainability and reducing energy costs.³⁵

AI can also enable autonomous systems that continuously optimize themselves. For instance, in plasma-assisted processes, AI can adjust electromagnetic fields to improve product yields while reducing energy use. This self-learning capability helps the system become more efficient with less human intervention.³⁶ By combining real-time data analytics, predictive modeling, and autonomous optimization, chemical plants can achieve unprecedented levels of efficiency and flexibility, all while reducing their environmental impact. This synergy is paving the way for fully integrated, flexible, resilient and sustainable processing systems.³⁷ Besides this integration between electrification and digitalization represents a fundamental shift in how chemical processes are designed, operated, and optimized.



3.5 Life cycle assessment (LCA) in carbon emissions reduction

The potential for carbon emissions reduction through electrification in process industries critically hinges on the source of electricity. In scenarios lacking reliable non-fossil energy supplies, substituting fossil fuels with electricity may yield limited or even unfavourable environmental outcomes. This underscores the necessity of evaluating such transitions from a full life cycle perspective—one that accounts for upstream emissions associated with power generation infrastructure and fuel supply.

Life cycle assessment (LCA) analyses corroborate this dependency:

- In the domain of carbon capture and utilization (CCU) within the chemical sector, the climate benefits of electrified technologies emerge significantly only when electricity exhibits a carbon intensity below certain threshold. Specifically, high-TRL CCU approaches begin to outperform conventional production when electricity emissions fall below approximately 260 g CO₂-eq. per kWh; for low-TRL approaches, even more stringent thresholds apply (44–334 g CO₂-eq. per kWh depending on product).³⁸

- In ammonia synthesis, electrolytic production powered entirely by renewable sources dramatically reduces emissions. LCA results indicate global warming potentials of 0.24–0.66 t CO₂-eq. per ton of NH₃ for wind, hydro, solar PV, and geothermal-powered electrolysis, in stark contrast to conventional steam methane reforming scenarios that range from 2.6 to 2.75 t CO₂-eq. per ton.³⁹

- A global outlook study projecting ammonia industry decarbonization reveals that, even under aggressive 1.5 °C-aligned scenarios, cumulative greenhouse gas emissions between 2020 and 2050 would amount to 15 Gt CO₂-eq.—substantially lower than higher warming trajectories (21–24 Gt CO₂-eq.)—but full decarbonization remains unlikely due to residual supply chain emissions.⁴⁰

- Broadly across the chemical industry, electrification combined with renewable integration could reduce sector-wide GHG emissions by at least 35%, particularly by addressing high-emission processes like ammonia, methanol, and olefin production. However, this potential is unlocked only under a deeply decarbonized power grid and through materials innovation, direct electrification of heat-intensive units, low-carbon hydrogen, and CCU deployment.³⁹

4. Case studies of process intensification through electrification

In previous sections it was discussed how to achieve more energy efficient, sustainable processes through process intensification and electrification. In this section are four case studies showing how electrification is changing key industrial operations.⁴¹

4.1 Case study 1: electrification of ammonia synthesis

The production of ammonia is one of the most energy-intensive processes in the chemical industry, traditionally using the



Fig. 1 Haber–Bosch process, (a) conventional, (b) indirectly electrified and (c) directly electrified.

Haber–Bosch (HB) method (Fig. 1) that operates at high pressures and temperatures (20 000 kPa ad 450 °C).⁴² In the conventional HB process, fossil fuels such as natural gas and coal are normally used as the energy sources for ammonia synthesis, releasing millions of tons of CO₂ to the atmosphere, which is about 1–2% of the global CO₂ emission.⁴³ The Haber–Bosch process is based on reduction reaction of N₂ as follows:



This reaction is highly exothermic however the reaction zone is not the most energy intensive of the overall process. The synthesis process can be divided into three stages: reaction gases obtention, compression and ammonia synthesis loop. The raw materials for ammonia production are water, air and natural gas. Nitrogen is obtained from air, and hydrogen is obtained by reforming natural gas. The heat required for the reformation of natural gas, which also is a highly endothermic process, is obtained by gas-fired burners. Before a second “reforming” stage (autothermal reforming) this first stage effluent is mixed with air, then a purification stage is necessary, first a WGSR process is used to convert CO into removable CO₂, and then MEA or DEA is used to remove this CO₂, however this process requires a regenerative column which also involves a considerable energy expense. Then to satisfy the purity requirements before reacting a methanation unit is used to remove any remaining trace of CO and CO₂. Being the obtaining reaction gases stage the most energy intensive. This is followed by the compression stage and then the synthesis loop which, as already mentioned, is carried out at high pressure and temperature and therefore also comprise a percentage of the energy expenditure of the overall process. Ammonia synthesis loops are complex recycling arrangements, where the ammonia



produced is separated by cooling and condensation, and the unreacted gas is recirculated back to the reactor along with fresh makeup gas. The synthesis loop arrangements differ in the points in the loop at which make-up gas is supplied, at which points ammonia is extracted and at which points purge gas is extracted.⁴⁴

The electrification of the ammonia synthesis process can be carried out in two ways: electrifying the stage of obtaining the reaction gases and electrifying the process directly. The first option involves only the stage of obtaining the reaction gases, the hydrogen is obtained by electrolysis of water, and the nitrogen in a separation unit, such as a cryogenic separation, electrically assisted. This avoids the major energy expenditure of the process since obtaining hydrogen represents about 90–95% of the total energy input for ammonia synthesis⁴⁵ and provides the opportunity to use renewable energy sources.

The direct electrification of the ammonia synthesis process is through the electroreduction of nitrogen in an electrochemical cell also known as eNRR (electrochemical N₂ reduction reaction). Mainly the electrosynthesis of ammonia is carried out in two types of cells, solid electrolyte and liquid electrolyte cells. The eNRR involves three elementary stages, first the diffusion and chemical adsorption of N₂ and protons (H⁺) on the cathode surface, then follows the stage of N₂ activation and the reductive action of hydrogen to form intermediates and product, and finally the stage of desorption and release of NH₃ from the electrode surface to the electrolyte.⁴⁶ This direct synthesis process is supposed to be less capital intensive than a combined water electrolysis with Haber–Bosch process, which is only about 40% energy efficient.⁴⁷ However, the eNRR has very low conversion rates which is the main drawback of this process. Fernández *et al.*,⁴⁸ proposed an optimization approach to compare an electrolyzer-assisted HB process using wind and solar energy to obtain hydrogen and an electrochemical black box synthesis of ammonia. Through this study, they found that the cost per ton of ammonia produced by the electrified HB process varies between 870 and 1600 USD, the highest price for ammonia recorded in recent years was 1600 USD per ton and the lowest 400 USD per ton, this price is strongly linked to the cost of natural gas which is the raw material and energy source in the conventional process. Therefore, the economic attractiveness of the electrified HB process will depend on natural gas price fluctuations even if this resource is not used in the process, while its feasibility will depend on the efficiency of the electrolyzer and future projections for cheaper electricity from renewable sources. For the case of the electrosynthesis process it was found that the cost per ton of ammonia produced varies between 570 and 1300 USD for the case of a minimum energy efficiency of 60%, and this process is more attractive in relation to the HB process if the price of natural gas remains above 30 USD per MMBtu. Meanwhile, Zhang *et al.*,⁴⁹ made a similar analysis between the conventional process and a power to ammonia process by replacing the natural gas reformer with a solid oxide electrolyzer and using a simulation approach, they found that for the conventional case there is an energy efficiency of 60%, a production cost per ton of ammonia of 400 USD and a payback

period of 5 years, while for the electrified process it reaches an efficiency of 75%, a payback period of 6 to 7 years and a production cost of 550 USD per ton of ammonia. In this sense, it also indicates the need to reduce the cost of renewable electricity, in this case reducing this price below 35 USD per MWh makes the process economically viable. Nami *et al.*⁵⁰ indicates that reducing the levelized cost of electricity from 60 to 10 € per MWh would decrease the cost of green ammonia from 690 to 340 € per t by 2050.

Regardless of the economic aspect, the CO₂ emissions should be considered, Dechany *et al.*⁵¹ stated that electrifying the ammonia synthesis process can actually be beneficial, cutting CO₂ emissions by up to 96 to 99% when using 100% renewable electricity rather than plugging into the grid, which currently runs primarily on fossil fuels. Additionally, these electrified processes have the possibility to be installed in a decentralized scheme which economically results in savings in transportation costs to the final consumer since in the centralized ammonia manufacturing the transportation costs can contribute more than 30% of the total fertilizer cost in certain regions. Comer *et al.*⁵² discuss the real effect of centralized production and the cost of transportation over different routes and distances and how it affects the cost of fertilizer. It is also important to highlight the play of economies of scale on production costs, since a conventional process for fertilizer synthesis is strongly linked to this concept and in countries such as Africa or Latin America, which are agriculture countries but without the necessary infrastructure for large-scale fertilizer manufacturing, the decentralized model may be more attractive. Another potential advantage of electroreduction is that different sources of nitrogen can be used, for example nitrate that can be recovered from wastewater,⁵³ and NO_x that can be captured from combustion processes,⁵⁴ making this a very cost-effective method.

4.2 Case study 2: evaluating the feasibility of electrification in methanol production

As industries transition toward sustainability, the question of whether to electrify chemical processes remains a critical one. Electrification can potentially reduce carbon emissions but comes at an economic cost that must be carefully evaluated. This case study examines methanol production as a representative example, analyzing the trade-offs between conventional and electrified processes. Specifically, we compare the traditional steam methane reforming (SMR) process with an electrified CO₂ hydrogenation pathway, assessing economic viability, energy consumption, and environmental impact based on data from Chen *et al.* (2019).⁵⁵ Through this case study, we determine under what conditions electrification is a feasible solution and where it may lead to economic inefficiencies.

Methanol production has traditionally relied on the reforming of natural gas with steam, a process that provides high hydrogen yield but is associated with significant CO₂ emissions due to fossil fuel combustion. The electrified alternative replaces fossil fuel-based hydrogen generation with electrolysis powered by renewable electricity, effectively



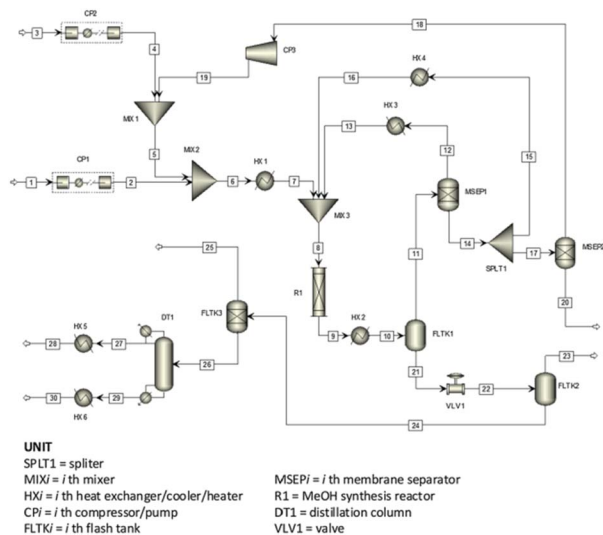

Fig. 2 Process flow diagram of the reference MeOH production plant simulated in Aspen Plus.

eliminating direct CO₂ emissions from fuel combustion. However, this transition comes with significant challenges, including high electricity demand and substantial capital investment for electrolysis infrastructure. The entire process to produce methanol is presented in Fig. 2.

According to Chen *et al.* (2019), energy and operational costs play a critical role in determining whether electrification is economically viable. The conventional SMR process requires substantial thermal energy, typically provided by natural gas combustion, while the electrified process shifts this demand entirely to electricity. The conventional process requires approximately 91.3 MW of thermal energy, whereas the electrified process replaces this with an electricity demand exceeding 600 MW. The elimination of fossil fuels in the electrified route significantly alters cost structures. The cost of natural gas for conventional production ranges between 6.5 and 8.5 € per GJ, while the cost of electricity required for electrolysis varies significantly depending on regional pricing. The break-even electricity cost for an electrified process is approximately 22 € per MWh, meaning that for electrification to be economically competitive, electricity must be available below this threshold. In most industrial settings, electricity costs remain above 30 € per MWh, making the electrified process more expensive than the conventional route. Both data for SMR-based process and electrified process are presented in Fig. 3.

Heating costs present another major consideration when evaluating electrification. In high-temperature operations such as methane reforming, steam heating is cost-effective and remains challenging to replace with electric alternatives due to the associated increase in operational costs. In contrast, for lower-temperature applications such as post-reactor purification steps or secondary heat exchange processes, electric heating offers better temperature control and process flexibility. Electrification is more feasible in these auxiliary systems where the energy demand is lower and the cost of implementing electric heating remains within a manageable range.



Fig. 3 Comparison of utility costs: SMR vs. electrified methanol production.

Additionally, Chen *et al.* (2019) performed an interesting sensitivity analysis. The sensitivity of the electrified process to various economic factors is critical to determining its feasibility. Electricity prices exert the most significant influence on production costs. When electricity costs exceed 50 € per MWh, the electrified process results in negative net present value and remains financially unsustainable. If electricity prices fall within the range of 20 to 25 € per MWh, electrification becomes economically neutral, matching the cost of conventional production. At prices below 4 € per MWh, electrification surpasses SMR-based production in profitability, making it the preferred alternative. This indicates that full electrification is only viable in regions with abundant, low-cost renewable electricity.

Methanol pricing also plays a significant role in determining the economic feasibility of electrification. If methanol prices rise beyond 500 € per t, the economic disadvantage of the electrified process diminishes, particularly if supported by carbon pricing mechanisms. Conversely, if methanol prices fall below 350 € per t, neither the conventional nor the electrified process remains attractive unless government incentives or subsidies offset the additional costs. Carbon pricing adds another layer of complexity to the feasibility of electrification. When carbon costs remain at 0 € per t CO₂, conventional production maintains a clear economic advantage. However, if carbon prices exceed 50 € per t CO₂, the electrified process becomes significantly more competitive, as carbon taxation increasingly penalizes fossil fuel-dependent operations. An interesting behaviour is observed in the electricity cost. In this scenario, the sensitivity analysis developed by Chen *et al.* (2019) is shown in Fig. 4.

An additional consideration is the level of renewable energy penetration in the electricity supply. Carbon neutrality in methanol production through electrification can only be achieved if at least 88% of the electricity used originates from renewable sources. At 100% renewable electricity, the electrified process enables CO₂ abatement of up to 1.35 kg per kg of methanol produced. However, if the electricity supply still relies on fossil fuels, the carbon reduction potential diminishes considerably, undermining one of the primary motivations for transitioning to an electrified process.



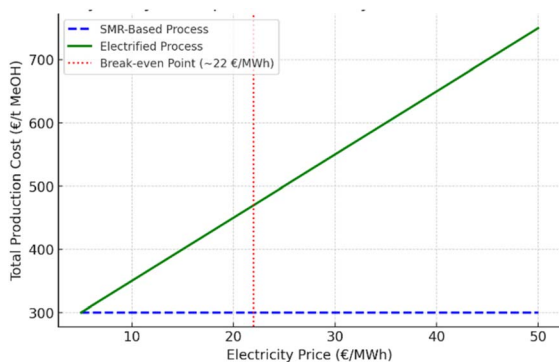

Fig. 4 Sensitivity analysis: impact of electricity prices on production costs.

The findings of this analysis suggest that electrification should be implemented selectively rather than universally. The replacement of major high-temperature process units, such as methane reformers, remains economically unviable due to the high operational and capital costs associated with electrolysis. In contrast, the electrification of auxiliary systems such as post-reactor purification, secondary heat exchangers, and low-energy-demand operations presents a viable and cost-effective approach to reducing carbon emissions without imposing prohibitive costs. The most pragmatic approach involves a hybrid strategy that retains fossil-fuel-based reforming while integrating renewable hydrogen production in a gradual transition toward full electrification. The feasibility of fully electrification remains highly dependent on regional electricity pricing, carbon policies, and market conditions. In areas where electricity prices are low and carbon taxation is high, full electrification may be a viable solution. However, in markets where electricity remains expensive, a selective electrification strategy is recommended to balance sustainability objectives with economic constraints. Future policy developments, advancements in renewable energy pricing, and improvements in electrolyzer efficiency will play a crucial role in determining the widespread adoption of electrification in methanol production.

4.3 Case study 3: electrified distillation: heat pump assisted distillation

Distillation is one of the most widely used separation techniques in the chemical industry, responsible for separating components in mixtures based on differences in volatility. However, it is energy-intensive, making up about 40% of energy consumption in the global chemical and petrochemical sectors. Traditional distillation processes rely heavily on the application of thermal energy to create vapor-liquid equilibria, typically achieved through steam or direct heating methods. Electrification of distillation operations consists of replacing the energy source for distillation with electricity derived from a renewable source, which offers a more energy efficient and sustainable alternative.⁵⁶

In this case, there are two ways of electrifying the distillation operations, the first one is direct electrification where the

heating equipment is replaced by electric heating equipment such as heat pumps, electric heaters (e-heaters), electrode boilers (e-boilers) or electric-furnaces (e-furnaces), also by applying direct heating inside the column as microwaves or an electrical field. The second is an indirect way where the electricity is used to produce a “green” fuel as hydrogen or methanol and then is used in conventional heating equipment.^{57,58} In the case of using e-heaters it is important to note that the efficiency of power to heat of these devices is very high, presenting coefficient of performance (COP) nearly to 1, which is logical, but no more, which, unlike other strategies, has no potential to improve energy efficiency.

In this sense, electrification strategies in distillation have been integrated with intensification strategies such as thermally coupled columns (TCDs), heat integrated distillation columns (HIDiC), columns with intermediate heat exchangers, heat pumps using vapor recompression (VR) and flash vapor circulation (FVC). This intensification makes it possible to improve the energy efficiency of the distillation process.

Heat Pump Assisted Distillation (HPAD) has been subject of many studies and has demonstrated the potential to reduce drastically the net energy consumption of the operation, in this scheme heat pumps where the top product can be compressed to a higher pressure and used to heat the bottom product, or the bottom product can be flashed in a valve and used to cool the top product.⁵⁹ In a Mechanical Vapor Recompression (MVR) scheme (Fig. 5), the vapor coming out of the top of the column is sent to a compressor, in this compression operation the vapor temperature also rises which makes the stream suitable to be used in the reboiler, this scheme may involve multiple stages of compression.

In MVR additional heating may be required to prevent liquid droplets from forming inside the compressor and, in addition the compressed vapor may not supply the net heating demand of reboiler, so, as an alternative, there is flash vapor circulation (FVC) which is designed to fully electrify distillation processes.⁶⁰ In this case a flash operation is used after the throttling valve, the flashed steam can be recirculated to the column or



Fig. 5 Heat pump assisted distillation with MVR.



recompressed thus generating more high-grade heat for be used in the reboiler.

Heat pump-assisted distillation has demonstrated significant potential to improve separation efficiency by reusing latent heat and reducing the overall reboiler duty. Reported coefficients of performance (COP) in the range of 4–5 are achievable, but these values are strongly dependent on operating conditions such as the temperature lift across the compressor, the type of working fluid, and the system configuration.⁵⁷ For instance, mechanical vapor recompression (MVR) distillation systems typically operate with a temperature rise of 10–30 K between the evaporator and the condenser, conditions under which COP values of 3.5–5.0 have been experimentally reported.^{61,62} The choice of working fluid is also critical: while water vapor is the most common in MVR distillation, alternative working fluids such as methanol–water mixtures or low-boiling organic fluids have been evaluated in thermally integrated distillation schemes to optimize both thermodynamic efficiency and process safety.⁶³

Experimental studies confirm these performance levels. Qi *et al.*⁶⁴ reported COP values close to 4.2 for an industrial-scale MVR ethanol–water distillation column with a 20 K temperature lift. Similarly, Cui *et al.*⁵⁷ demonstrated a COP of 4.6 in a pilot-scale methanol–water distillation system using vapor recompression with a temperature rise of 25 K. More recently, Wang *et al.*⁶³ showed that integrating organic working fluids into hybrid heat pump–distillation cycles can extend achievable COP values up to 5.0, particularly when the temperature lift is maintained below 30 K.

As for the economic aspect, Cui *et al.* presented an economic analysis of three different separations: methyltrichlorosilane/dimethylchlorosilane, methylcyclopentane/cyclohexane and isobutanol/*n*-butanol, by conventional distillation, MVR, double effect distillation and distillation with a recycle process.

These results illustrate that the energy efficiency of heat pump distillation is not a fixed value but rather a function of system design, working fluid selection, and operating conditions. Clear specification of these parameters is therefore essential when assessing the applicability of heat pump-assisted separation in industrial practice; in all three separations the MVR scheme is better in economic terms representing savings of up to 30% of the TAC of the separation.

Replacing the work done by steam heating for electrical power also represents CO₂ emissions cuttings. The comparison between the emissions of a conventional distillation system and a HPAD can be approximated as below:⁵⁷

$$\gamma = \left[1 - \frac{C_{\text{grid}}}{(C_{\text{steam}})(\text{COP})} \right] \times 100$$

where C_{grid} and C_{steam} are the CO₂ emitted by using electricity and steam heating respectively. From this equation even with COPs lower than 4, it is possible to have significant emissions cuts, except when the reboiler requires high temperatures (above 200 °C) and the grid presents greater carbon emissions.

Even more HPAD schemes are more cost efficient and easy to operate due to their simple design, also it is recognized that the retrofitting of a conventional distillation scheme to a HPAD is relatively easy compared to other heat integration schemes.⁶⁵

Electrified distillation provides more precise control over heating, leading to significant energy savings. Electric systems like resistive or inductive heating can apply heat directly where it's needed, minimizing losses that are common with steam-based methods. This control also helps match energy input with the separation process, cutting excess heating and avoiding wasted energy. Electric heating systems also respond faster, enabling quicker start-ups, shutdowns, and greater operational efficiency, especially during low-load periods.⁶⁶

Another advantage of electrified distillation is its potential to be powered by renewable energy sources, such as solar, wind, or hydropower. This shift reduces the carbon footprint of distillation processes, helping industries meet sustainability goals and comply with stricter environmental regulations.⁶⁷ Besides, electrified distillation also allows for more flexible and modular production systems. Small-scale, on-demand manufacturing can be more easily integrated into decentralized production models, which are becoming more popular in industries that prioritize flexibility over large, centralized plants.

4.4 From laboratory to pilot plant

Recent years have witnessed the transition of electrification concepts from laboratory and pilot research toward industrial-scale implementation in the chemical sector. For instance, electrified steam cracking—one of the most energy-intensive processes in petrochemicals—is being demonstrated at pilot scale in Europe by initiatives such as BASF, SABIC, and Linde, where resistive heating replaces conventional fossil-fuel combustion to supply high-temperature process heat.^{68–70}

4.4.1 Electrified steam cracking (e-cracking) in petrochemicals (Europe). In 2024, BASF, SABIC, and Linde inaugurated the world's first large-scale demonstration plant in Ludwigshafen, Germany, where steam cracking furnaces are powered electrically *via* 6 MW of renewable energy. The technology enables a potential CO₂ reduction of up to 90% compared to conventional fossil-fuel combustion. Similarly, Dow and Shell have launched pilot e-cracking furnaces in Amsterdam, targeting retrofit potential for existing crackers.

4.4.2 Electrified membrane processes for CO₂ separation. While specific industrial-scale membrane CO₂ separation systems remain emerging, sector-wide momentum is increasing. Notably, e-methanol production plants in Denmark utilize captured CO₂ combined with renewable electricity, highlighting industrial uptake of electrified carbon utilization pathways.

4.4.3 Electrolysis-based hydrogen integrated into ammonia plants (Europe, India, global). • Yara, Herøya (Norway): in June 2024, Yara launched Europe's largest PEM electrolyzer (24 MW) at its Porsgrunn site. The green hydrogen produced—approximately 10 000 kg per day—is integrated into ammonia production, replacing ethane feedstock and reducing CO₂ emissions by ~41 000 t per year. Green ammonia fertilizers are already being delivered to market.

• Fertiberia, Puertollano (Spain): Fertiberia operates a green hydrogen and ammonia facility supplied by renewable energy, producing 100% sustainable fertilizer solutions (“Impact Zero”)



and aiming for up to 2.5 million tonnes per year of low-carbon ammonia across its projects.

- Global electrolysis-ammonia projects: ACME Group (India) operates a 4 MW alkaline electrolyzer in Bikaner (~1500 t NH₃ per year); Iberdrola–Fertiberia (Spain) run the H₂F plant (20 MW PEM electrolyzer), producing ~17 000 t NH₃ per year; Fertiglobe (Egypt) commissioned a 5 MW PEM system (~4500 t NH₃ per year); Brazil's Unigel is deploying 60 MW electrolyzers for ~60 000 t NH₃ per year; multiple projects in the US by CF Industries and LSB Industries target 20–30 MW capacities for similar scale.

4.4.4 Green hydrogen and ammonia mega-projects (global, Asia). • Saudi Arabia, NEOM Green Hydrogen Project: slated to become the largest utility-scale green hydrogen complex, it will combine ~3.9 GW of solar and wind power to produce 600 t per day of hydrogen and 1.2 million t per year of green ammonia by 2026–2027.

- Oman & Malaysia: Oman aims for up to 9 million t per year of green hydrogen by 2050; Malaysia's H2biscus project plans to produce green and blue ammonia and methanol, with thousands of tonnes of green H₂ and up to ~630 000 t green ammonia per year.

- Floating green ammonia facility (Netherlands/Norway): the OFFSET project led by Switch2 BV and BW Offshore is developing a floating plant linked to offshore wind, producing green hydrogen and ammonia for shoreline delivery *via* pipelines and tankers by around 2027.

5. Renewable energy integration

Coupling renewable energy sources with intensified processes in chemical production presents a significant opportunity for emissions reduction and optimized resource utilization. The integration of renewable energy sources, such as solar and wind, into electrified industrial systems introduces variability due to their inherent intermittency. This variability poses challenges to the stability and reliability of these systems, necessitating robust solutions to manage fluctuations and ensure continuous operation. Renewable energy sources are characterized by fluctuations in power generation, influenced by factors such as weather conditions and diurnal cycles. This intermittency can lead to mismatches between energy supply and industrial demand, potentially disrupting operations. Periods of low wind or solar activity may result in insufficient power generation, while peak production times may produce excess energy beyond immediate requirements. Such imbalances underscore the need for strategies to harmonize energy supply with industrial energy demands.⁷¹

To address the challenges posed by renewable energy intermittency, several strategies have been proposed and implemented. One of the most effective solutions involves the deployment of energy storage systems, such as battery energy storage systems (BESS). These systems accumulate excess energy during periods of high renewable output, which can then be utilized during low production phases. This approach enhances grid stability and ensures a reliable energy supply for industrial processes. Recent advancements have led to significant growth in battery storage capacity, with projections

indicating that storage additions will outpace new fossil fuel power plants by 2030.⁷² In addition to batteries, alternative energy storage solutions such as thermal batteries and chemical storage have gained attention. Thermal batteries store excess electricity as heat, which can later be converted back into electricity or used directly in industrial processes. Chemical storage, including the production of hydrogen *via* electrolysis, provides a means to store energy in a form that can be utilized as a fuel or feedstock in various industrial applications.⁷³

Another strategy to manage intermittency is flexible demand management. Industries can adapt their energy consumption patterns to align with the availability of renewable energy by modulating industrial processes to operate during periods of high energy availability and reducing activity during low supply intervals. This demand-side flexibility significantly reduces residual peak load and excess generation, thereby enhancing the integration of fluctuating renewables.⁷⁴ While these strategies improve the stability of electrified systems, the current state of renewable energy technology and storage solutions may not fully guarantee uninterrupted power supply due to the variability of renewable sources. Consequently, backup systems remain essential to ensure operational continuity. Maintaining a connection to the traditional power grid allows industries to draw electricity during periods when renewable sources and on-site storage are insufficient. This hybrid approach leverages the reliability of the grid while maximizing the use of renewable energy. Additionally, industries may invest in on-site backup generators powered by alternative fuels, such as natural gas or biofuels, to provide immediate power during deficits in renewable energy supply. While this introduces some reliance on fossil fuels, it ensures the resilience of industrial operations.

Integrating renewable energy into electrified processes requires the development of intelligent energy management systems that optimize energy consumption based on real-time supply and demand dynamics. These advanced systems can monitor energy generation from renewable sources and adjust chemical production processes, accordingly, thereby maximizing efficiency. For instance, during periods of high renewable energy availability, chemical plants can increase production rates or utilize excess energy for energy-intensive processes, minimizing waste and reducing operational costs.

The flexibility afforded by integrating renewable energy sources is particularly crucial in a landscape characterized by intermittent energy supply. Unlike traditional fossil fuel systems, which provide consistent power, renewable energy generation can fluctuate based on weather conditions and time of day. Intelligent energy management systems can help mitigate these fluctuations by incorporating energy storage solutions, such as batteries or thermal storage, to ensure a stable energy supply. By maintaining a consistent energy flow, chemical plants can operate more reliably and efficiently, aligning production schedules with renewable energy availability.⁷⁵

Moreover, electrification enables the direct use of renewable electricity in various chemical processes, fostering a more sustainable approach to chemical manufacturing. For example, green hydrogen produced *via* electrolysis powered by renewable electricity can serve as a clean feedstock for ammonia synthesis



and other essential chemicals. This not only reduces carbon emissions associated with hydrogen production, traditionally derived from natural gas, but also supports the development of low-carbon fertilizers and fuels, further enhancing the sustainability of chemical production.

The integration of renewable energy sources, such as solar and wind, into electrified industrial systems introduces variability due to their inherent intermittency. This variability poses challenges to the stability and reliability of these systems, necessitating robust solutions to manage fluctuations and ensure continuous operation. Renewable energy sources are characterized by fluctuations in power generation, influenced by factors such as weather conditions and diurnal cycles. This intermittency can lead to mismatches between energy supply and industrial demand, potentially disrupting operations. Periods of low wind or solar activity may result in insufficient power generation, while peak production times may produce excess energy beyond immediate requirements. Such imbalances underscore the need for strategies to harmonize energy supply with industrial energy demands.⁷¹

6. Challenges in implementing electrification for process intensification

Despite the significant advantages of electrification for process intensification, several challenges must be addressed to facilitate its widespread adoption within the chemical industry. These challenges encompass technological, economic, and regulatory dimensions, each playing a critical role in determining the success of electrification initiatives.

6.1 Technological integration barriers

Integrating electrification technologies into existing chemical processes can be complex, particularly for high-temperature and energy-intensive operations. Many traditional systems were designed with fossil fuel-based heating and processing in mind, necessitating substantial modifications to accommodate electrified processes. This retrofitting involves not only technical challenges but also economic hurdles, as it requires significant investment in new equipment, training for personnel, and potential downtime during the transition. As a result, companies may hesitate to invest in electrification due to concerns over disruption and return on investment.⁷⁶ Moreover, the technical intricacies of electrified processes often require specialized knowledge and expertise that may not be readily available within the existing workforce. This gap highlights the need for targeted training programs and knowledge-sharing initiatives to equip engineers and operators with the skills necessary to implement and manage electrified systems effectively.

6.2 Scalability and flexibility

Scaling up electrification technologies for large-scale operations presents another challenge. While laboratory-scale experiments

may demonstrate the efficacy of electrified processes, translating these innovations to industrial-scale operations can be fraught with difficulties. The inherent complexities of scaling often lead to unforeseen operational issues, such as variations in performance, safety concerns, and the need for additional infrastructure.

Ensuring flexibility in production rates while maintaining efficiency during the transition to electrified systems is crucial for achieving operational goals. Chemical plants must be capable of adapting their processes to varying demand without compromising quality or safety. This flexibility is particularly important in industries characterized by fluctuating market conditions and the need for rapid responses to changing consumer preferences.⁷⁷

6.3 Energy storage and grid reliability

A critical challenge for implementing electrification at scale lies in ensuring the reliability and stability of electricity supply. While renewable sources such as solar and wind are essential for decarbonization, their intermittency exposes chemical processes to risks of fluctuation, disruption, or unplanned shutdowns. This creates a pressing need for robust grid infrastructures capable of balancing variable generation with industrial demand. One of the main hurdles is the current limitation of large-scale, cost-effective energy storage technologies, which remain insufficient to guarantee uninterrupted operation during prolonged periods of low renewable output. Additionally, dependence on regional grid stability can constrain investment in electrified plants, particularly in regions where infrastructure is weak or fossil-based generation is still dominant. Overcoming these challenges requires not only advances in storage capacity and smart grid deployment but also coordinated policy and market mechanisms that prioritize industrial reliability, ensuring that electrification can move from demonstration projects to full-scale industrial implementation.⁷⁸

6.4 Material compatibility

Transitioning to electrically driven processes may raise concerns regarding material compatibility and durability. The high temperatures and reactive environments associated with many chemical processes can pose risks to the longevity and performance of materials used in electrified systems. Ensuring that materials can withstand these operational conditions without degradation is paramount for maintaining safety and efficiency. R&D efforts must focus on identifying and developing materials specifically designed for electrified processes. This includes the exploration of advanced alloys, composites, and coatings that can endure harsh conditions while maximizing performance. Collaboration between material scientists and chemical engineers will be essential to advance innovations in this area.⁷

Material compatibility remains a pivotal concern for long-term stability in high-temperature electrified systems, particularly within solid oxide electrolysis cells (SOECs). Recent literature elucidates several critical degradation pathways:



- Delamination and nanopore formation at the air-electrode/electrolyte interface: Choi *et al.* (2024) used high-resolution TEM and DFT calculations to reveal that accumulation of excess oxygen ions near the LSM (lanthanum strontium manganite)–YSZ (yttria-stabilized zirconia) interface creates lattice strain, dislocations, and nanopores that evolve into cracks and eventually cause electrode delamination.⁷⁹

- Agglomeration and depletion of Ni in Ni–YSZ cathodes: long-duration SOEC operation (*e.g.*, 9000 h at ~780 °C, 1 A cm⁻²) leads to nickel depletion at the cathode/electrolyte boundary and formation of dense Ni/YSZ layers, causing significant loss of triple-phase boundary length and degradation in electrochemical performance.⁷⁹

- Volatilization and poisoning by chromium species: chromium evaporates from ferritic steel interconnects and deposits on LSM-type cathodes, forming SrCrO₄ and spinel (Cr,Mn)₃O₄ phases that block active reaction sites and impair cell efficiency.

- Ni–YSZ electrode degradation *via* coarsening, redox cycling, and carbon deposition: degradation in SOFC/SOEC Ni–YSZ electrodes includes nickel particle coarsening, redox-induced volume changes causing mechanical stress, as well as cooking when hydrocarbon feeds are used—each contributing to performance decline.⁸⁰

- Thermal stress and stack component failure: metal-supported SOEC stacks designed to mitigate thermal-gradient-induced fracture of brittle ceramics still face degradation from high-temperature oxidation and stress, particularly in interconnects and sealants, under dual atmospheres.⁸⁰

These degradation mechanisms emphasize the necessity of material innovation. Mitigation strategies being explored include the application of protective spinel or alumina coatings to inhibit chromium poisoning, compositional tuning of electrodes and interconnects to enhance redox and thermal stability, and development of ceramic composites with improved mechanical resilience. Additionally, advanced *in situ* and *operando* characterization methods—such as TEM, Raman spectroscopy, and synchrotron XAS—are increasingly crucial for unraveling real-time degradation and guiding design of more durable materials.

7. Policy, economic, and infrastructure considerations

As the chemical industry embarks on a transformative journey toward electrification and process intensification, understanding the multifaceted policy, economic, and infrastructure considerations becomes imperative.

7.1 Policies

A strong policy framework is essential to accelerate the adoption of electrified processes in the chemical industry. Governments play a key role by supporting research, innovation, and investment through targeted incentives like tax breaks, grants, and subsidies.²¹ For example, the European Union's Innovation Fund, one of the largest of its kind, is allocating €10 billion from 2020 to 2030 to support

technologies such as electrified steam cracking and electrochemical production.⁸¹

Market-based tools like the EU Emissions Trading System and the Carbon Border Adjustment Mechanism encourage companies to transition to cleaner technologies. China, responsible for 40% of global chemical output, has committed to industrial electrification as part of its 2060 carbon neutrality goal, dedicating over €13 billion to decarbonization subsidies, much of which supports electrified chemical processes.⁸²

Incentives that reduce capital and operational costs are vital to making electrification economically viable and accelerating deployment.⁸³ However, harmonizing standards across regions is equally important. Without consistent technical guidelines, fragmented regulations can drive up costs and delay implementation. Studies indicate that regulatory misalignment can raise compliance costs by up to 30%.⁸⁴

International initiatives help bridge these gaps. The Mission Innovation Industrial Decarbonization Initiative (MI-IDI), launched in 2021 with 22 countries, is investing \$3 billion in technologies like electrified heat and green hydrogen.⁸⁵ Similarly, the EU-U.S. Green Technology Partnership (2022) is funding €1.5 billion in joint decarbonization projects. The China-Pakistan Economic Corridor (CPEC) shows how coordinated efforts can reduce industrial energy costs, in this case by 15%, through improved grid integration and renewable use.⁸⁶

7.2 Economics

The economic case for electrification must be evaluated through comprehensive cost-benefit analysis. While initial investment can be high, long-term savings from improved energy efficiency, lower emissions compliance costs, and decreasing renewable energy prices make electrified systems increasingly attractive.⁸⁷

Electrification enhances operational stability by reducing exposure to fossil fuel price volatility. It can also improve product quality and consistency, cutting waste and rework critically in precision industries like pharmaceuticals and specialty chemicals.⁸⁸ Additionally, companies adopting cleaner technologies benefit from stronger public perception and greater access to environmentally conscious markets.²³

Infrastructure readiness is equally vital. Expanding grid capacity, modernizing transmission networks, and adopting smart grid technologies are necessary to support growing electricity demands.⁸¹ Investment in energy storage such as batteries is key to managing renewable intermittency and ensuring continuous industrial operation. Decentralized energy systems further boost reliability, especially in remote or underserved regions.⁸⁹

Under current market conditions, electrification often bears a cost premium. Key contributing factors include higher electricity prices, significant capital expenditures for electrified equipment (*e.g.*, electrolyzers, electric furnaces), and underdeveloped markets for low-carbon products.

However, real-world and analytical evidence show that economic competitiveness is improving under specific conditions:^{90–92}



(1) High cost of renewable deployment and energy demand: a recent analysis by Accenture estimates that decarbonizing the European chemicals sector *via* electrification would require an estimated 3.2 PW h of additional renewable electricity—equivalent to, for example, covering all of Spain with wind turbines. The cost for such a deployment is approximately 1 trillion euros, placing a substantial economic burden on electrification strategies unless renewable energy prices decrease or regulatory support increases.

(2) Cost barriers in green hydrogen production: the economics of green hydrogen remain a central challenge for electrification in hard-to-electrify sectors. The Financial Times reports that the levelized cost of green hydrogen currently ranges between \$4.50 and \$6.50 per kg, translating to approximately \$200 per MWh of hydrogen energy. This places it significantly above conventional natural gas (\approx \$8 per MWh in the U.S.) and even grey hydrogen (\approx €80 per MWh in Europe), yielding a substantial “green premium” of around €105 per MWh.

(3) Declining costs and potential for parity: despite current disparities, projections show a path toward economic viability. A techno-economic analysis indicates that green hydrogen can achieve cost parity with fossil-based hydrogen if electricity costs fall below \$20–30 per MWh, supported by improvements in electrolyzer efficiency, economies of scale, and policy incentives like tax credits (*e.g.*, IRA providing up to \$3 per kg).

Addressing these infrastructure challenges requires cross-sector collaboration. Public funding can stimulate necessary upgrades, while private partnerships and academic research can drive innovation in energy storage and management systems.¹⁷

7.3 Infrastructure

Integrating electrified processes into existing industrial systems poses logistical and technical challenges, requiring careful planning and substantial investment. Retrofitting facilities often demands significant equipment and workflow changes, which can cause temporary disruptions but offer long-term gains in efficiency and emissions reduction.⁴

A major area of focus is process heating, a large energy consumer in the chemical industry. Replacing fossil-fuel systems with electric technologies like boilers, heat pumps, and induction heaters necessitates substantial infrastructure upgrades, including enhanced electrical supply networks. Though costly, this transition is vital for decarbonizing industrial heat.⁹³

Electrochemical reactors also play a growing role, offering improved efficiency and selectivity for chemical production. However, varying levels of technological maturity mean continued R&D is needed for broader implementation.⁹⁴

Additionally, electrification increases demand for electrical infrastructure. Upgrading power distribution systems transformers, switchgear, and wiring is essential. To ensure reliable and sustainable operation, the integration of renewable energy sources and energy storage systems is critical.⁹⁴

7.4 Sector-specific adaptations

7.4.1 Petrochemical industry. Electrifying high-energy processes like steam cracking involves the development of

electric steam crackers and electric drive systems for pumps and compressors. These changes require major capital investment and innovation to enhance efficiency and reduce emissions.⁹⁵

7.4.2 Pharmaceutical industry. Though less energy-intensive, pharmaceutical production demands precise control. Electrification focuses on electric heating for reactors and advanced control technologies, with strict adherence to industry-specific regulatory standards.⁹⁶

8. Future directions and research needs

As the chemical industry advances toward electrification and process intensification (PI), several research priorities will be essential. A key focus is the development of next-generation electrochemical technologies that improve reaction efficiency and selectivity.⁹⁷ This includes innovations in catalyst design—such as the use of novel materials like metal–organic frameworks (MOFs) and deeper exploration of electron transfer mechanisms to enable new, more efficient reaction pathways.

Machine learning and artificial intelligence can accelerate the design and optimization of electrochemical systems by predicting reaction behaviours and outcomes. In parallel, coupling electrified processes with renewable energy sources like solar and wind will be critical for reducing emissions and costs. To address the intermittent nature of renewables, research must advance energy storage technologies, including high-density batteries and supercapacitors, to ensure stable, reliable operation.⁹⁸

Collaboration across industry, academia, and government is vital for driving innovation and technology adoption. Joint research initiatives can pool expertise and resources, enabling the development of comprehensive solutions while accessing broader funding opportunities. International and cross-sector partnerships also promote knowledge exchange; help standardize best practices and accelerate the global rollout of electrified processes.⁹⁹

Pilot and demonstration projects are crucial for testing and validating new technologies on an industrial scale. These projects help assess performance, optimize processes, and identify operational challenges before large-scale deployment. Their outcomes can serve as valuable case studies, informing future facility designs, shaping policy support, and encouraging broader industry adoption. Sharing results through conferences and publications contributes to building a shared knowledge base that supports ongoing improvement and innovation.¹⁰⁰

Focusing on these research and implementation strategies will enhance the chemical industry's efficiency, resilience, and environmental performance. Continued commitment to innovation and collaboration will be key to achieving a carbon-neutral and sustainable future.¹⁰¹

9. Conclusions

In summary, electrification presents a transformative opportunity for process intensification across the chemical industry,



driving significant advancements in energy efficiency, sustainability, and overall operational effectiveness. Key insights from this exploration highlight several critical areas where electrification can make a substantial impact. First, the integration of electrified reaction pathways, such as electrochemical synthesis and plasma technologies, not only reduces energy consumption but also enhances selectivity and yields in chemical processes. These technologies allow for reactions to occur under milder conditions, unlocking novel pathways that conventional methods cannot achieve, ultimately leading to greener and more efficient production processes.¹⁰²

Furthermore, electrification facilitates the consolidation of complex operations, streamlining traditional processes by minimizing the number of reaction and separation steps. This reduction enhances throughput while simultaneously decreasing capital expenditures and operational complexity. The potential to design more compact and efficient chemical plants is particularly relevant in the context of distributed production systems, where smaller-scale operations can be more easily implemented and managed.

Despite these promising advantages, the journey toward electrified processes is fraught with challenges. One of the primary hurdles is the need for significant upgrades to existing infrastructure. The chemical industry must invest in modernizing electrical grids and ensuring a reliable supply of renewable energy sources to support the widespread implementation of electrified processes. Moreover, the economic viability of transitioning to electrified systems necessitates comprehensive cost-benefit analyses to ensure that these investments yield long-term sustainability and competitiveness in an evolving market.⁵

The potential for electrification to contribute to carbon neutrality in the chemical industry is immense, but realizing this potential requires a collective effort. Collaborative industry partnerships and research institutions play a crucial role in advancing the electrification of intensified processes. By fostering innovation and facilitating knowledge sharing, these collaborations can help overcome technical barriers and accelerate the adoption of new technologies. Furthermore, supportive policy development and regulatory measures will be essential to incentivize the uptake of electrified technologies. Mechanisms such as carbon pricing and financial incentives for adopting low-carbon processes can stimulate industry engagement and investment.

While the opportunities presented by process intensification through electrification are significant, it is essential to recognize the limitations and challenges inherent in this transition. Factors such as the scalability of new technologies, the initial capital investment required, and the readiness of the existing workforce to adapt to new processes must all be considered. Additionally, potential trade-offs between the efficiency of electrified processes and the economic implications of their implementation need to be critically evaluated.

In conclusion, harnessing the full potential of electrification for process intensification is not only a pathway toward enhanced operational efficiency but also a crucial step in achieving carbon neutrality. By committing to ongoing research, industry collaboration, and robust policy frameworks,

the chemical industry can lead the change in transforming its processes to meet the demands of a sustainable future. The journey toward electrified and intensified processes presents both challenges and opportunities that, if effectively managed, can yield substantial environmental and economic benefits, paving the way for a more sustainable chemical industry.

Author contributions

Juan Gabriel Segovia Hernández: conceptualization, investigation, methodology, supervision, writing – original draft. Jesús Manuel Núñez López: investigation, validation, writing – review & editing. Enrique Cossio Vargas: conceptualization, investigation, methodology, validation. Maricruz Juárez García: investigation, methodology, visualization, writing – review & editing. Eduardo Sánchez Ramírez: conceptualization, investigation, methodology, validation, writing – original draft.

Conflicts of interest

The authors declare that they have no known competing financial interests or personal relationships that could have appeared to influence the work reported in this paper.

Data availability

No primary research results, software or code have been included, and no new data were generated or analysed as part of this review.

Acknowledgements

To the Universidad de Guanajuato (México) for its support.

References

- 1 K. M. Van Geem and B. M. Weckhuysen, Toward an e-chemistree: materials for electrification of the chemical industry, *MRS Bull.*, 2021, **46**(12), 1187–1196.
- 2 J. L. Barton, Electrification of the chemical industry, *Science*, 2020, **368**, 1181–1182.
- 3 J. G. Segovia-Hernández, S. Hernández, E. Cossio-Vargas and E. Sánchez-Ramírez, Challenges and opportunities in process intensification to achieve the UN's 2030 agenda: goals 6, 7, 9, 12 and 13, *Chem. Eng. Process.*, 2023, **192**, 109507.
- 4 Z. J. Schiffer and K. Manthiram, Electrification and Decarbonization of the Chemical Industry, *Joule*, 2017, **1**, 10–14.
- 5 M. Wei, C. A. McMillan and S. d. I. R. du Can, Electrification of Industry: Potential, Challenges and Outlook, *Curr. Sustainable/Renewable Energy Rep.*, 2019, **6**, 140–148.
- 6 C. Chen, Y. Lu and R. Banares-Alcantara, Direct and indirect electrification of chemical industry using methanol production as a case study, *Appl. Energy*, 2019, **243**, 71–90.
- 7 G. J. Van Rooij, H. N. Akse, W. A. Bongers and M. C. M. Van De Sanden, Plasma for electrification of chemical industry:



- a case study on CO₂ reduction, *Plasma Phys. Controlled Fusion*, 2017, **60**, 014019.
- 8 D. Brough and H. Jouhara, The aluminium industry: a review on state-of-the-art technologies, environmental impacts and possibilities for waste heat recovery, *Int. J. Thermofluids*, 2020, **1–2**, 100007.
 - 9 T. Kochenburger, G. Liesche, J. Brinkmann, K. Gagalick and D. Förtsch, Fine chemicals production in a carbon-neutral economy: the role of electrification, *Curr. Opin. Chem. Eng.*, 2023, **40**, 100904.
 - 10 C. Coutanceau, S. Baranton and R. S. B. Kouamé, Selective electrooxidation of glycerol into value-added chemicals: a short overview, *Front. Chem.*, 2019, **7**, 438544.
 - 11 T. Schultz, M. Nagel, T. Engenhorst, A. Nymand-Andersen, E. Kunze, P. Stenner and J. E. Lang, Electrifying chemistry: a company strategy perspective, *Curr. Opin. Chem. Eng.*, 2023, **40**, 100916.
 - 12 A. Al Moinee, A. A. Rownaghi and F. Rezaei, Challenges and Opportunities in Electrification of Adsorptive Separation Processes, *ACS Energy Lett.*, 2024, **9**, 1228–1248.
 - 13 M. R. Allen, P. Friedlingstein, C. A. Girardin, S. Jenkins, Y. Malhi, E. Mitchell-Larson and L. Rajamani, Net Zero: Science, Origins, and Implications, *Annu. Rev. Environ. Resour.*, 2022, **47**, 849–887.
 - 14 N. Stern and A. Valero, Innovation, growth and the transition to net-zero emissions, *Resour. Policy*, 2021, **50**, 104293.
 - 15 T. A. Tsalis, K. E. Malamateniou, D. Koulouriotis and I. E. Nikolaou, New challenges for corporate sustainability reporting: United Nations' 2030 Agenda for sustainable development and the sustainable development goals, *Corp. Soc. Responsib. Environ. Manag.*, 2020, **27**, 1617–1629.
 - 16 T. Bennich, S. Belyazid, I. Stjernquist, A. Diemer, S. Seifollahi-Aghmiuni and Z. Kalantari, The bio-based economy, 2030 Agenda, and strong sustainability – a regional-scale assessment of sustainability goal interactions, *J. Clean. Prod.*, 2021, **283**, 125174.
 - 17 R. Chaudhury, U. Sharma, P. C. Thapliyal and L. P. Singh, Low-CO₂ emission strategies to achieve net zero target in cement sector, *J. Clean. Prod.*, 2023, **417**, 137466.
 - 18 P. Glavič, Z. N. Pintarič, H. Levičnik, V. Dragojlović and M. Bogataj, Transitioning towards Net-Zero Emissions in Chemical and Process Industries: A Holistic Perspective, *Processes*, 2023, **11**, 2647.
 - 19 E. A. López-Guajardo, *et al.*, Process intensification 4.0: a new approach for attaining new, sustainable and circular processes enabled by machine learning, *Chem. Eng. Process.*, 2022, **180**, 108671.
 - 20 P. Gabrielli, H. Goericke and L. Rosa, Optimal Combination of Net-Zero Pathways for Minimum Energy, Land, and Water Consumption in Chemical Production, *Ind. Eng. Chem. Res.*, 2024, **63**, 13929–13942.
 - 21 T. G. Walmsley, P. S. Varbanov, R. Su, B. Ong and N. Lal, Frontiers in process development, integration and intensification for circular life cycles and reduced emissions, *J. Clean. Prod.*, 2018, **201**, 178–191.
 - 22 Y. Demirel and M. A. Rosen, *Sustainable Engineering: Process Intensification, Energy Analysis, and Artificial Intelligence*, 2023, pp. 1–424, DOI: [10.1201/9781003191124](https://doi.org/10.1201/9781003191124).
 - 23 C. A. del Pozo, S. Cloete and Á. J. Álvaro, Carbon-negative hydrogen: exploring the techno-economic potential of biomass co-gasification with CO₂ capture, *Energy Convers. Manag.*, 2021, **247**, 114712.
 - 24 G. P. Thiel and A. K. Stark, To decarbonize industry, we must decarbonize heat, *Joule*, 2021, **5**, 531–550.
 - 25 W. Yao, L. Liu, H. Fujii and L. Li, Digitalization and net-zero carbon: the role of industrial robots towards carbon dioxide emission reduction, *J. Clean. Prod.*, 2024, **450**, 141820.
 - 26 M. H. de Sá, Electrochemical Devices to Power a Sustainable Energy Transition—An Overview of Green Hydrogen Contribution, *Appl. Sci.*, 2024, **14**, 2168.
 - 27 D. J. Arent, P. Green, Z. Abdullah, T. Barnes, S. Bauer, A. Bernstein and C. Turchi, Challenges and opportunities in decarbonizing the U.S. energy system, *Renew. Sustain. Energy Rev.*, 2022, **169**, 112939.
 - 28 P. S. Varbanov, B. Wang, P. Oclon, E. Radziszewska-Zielina, T. Ma, J. J. Klemes and X. Jia, Efficiency measures for energy supply and use aiming for a clean circular economy, *Energy*, 2023, **283**, 129035.
 - 29 K. Bayne and A. Renwick, Beyond Sustainable Intensification: Transitioning Primary Sectors through Reconfiguring Land-Use, *Sustainability*, 2021, **13**, 3225.
 - 30 J. D. Sachs, G. Schmidt-Traub, M. Mazzucato, D. Messner, N. Nakicenovic and J. Rockstrom, Six Transformations to achieve the Sustainable Development Goals, *Nat Sustainability*, 2019, **2**(9), 805–814.
 - 31 T. A. Tsalis, K. E. Malamateniou, D. Koulouriotis and I. E. Nikolaou, New challenges for corporate sustainability reporting: United Nations' 2030 Agenda for sustainable development and the sustainable development goals, *Corp. Soc. Responsib. Environ. Manag.*, 2020, **27**, 1617–1629.
 - 32 A. Khajuria, V. A. Atienza, S. Chavanich, W. Henning, I. Islam, U. Kral and J. Li, Accelerating circular economy solutions to achieve the 2030 agenda for sustainable development goals, *Circular Economy*, 2022, **1**, 100001.
 - 33 J. Li, S. Shirowzhan, G. Pignatta and S. M. E. Sepasgozar, Data-Driven Net-Zero Carbon Monitoring: Applications of Geographic Information Systems, Building Information Modelling, Remote Sensing, and Artificial Intelligence for Sustainable and Resilient Cities, *Sustainability*, 2024, **16**, 6285.
 - 34 A. Di Vaio, R. Palladino, R. Hassan and O. Escobar, Artificial intelligence and business models in the sustainable development goals perspective: a systematic literature review, *J. Bus. Res.*, 2020, **121**, 283–314.
 - 35 P. P. Walsh, E. Murphy and D. Horan, The role of science, technology and innovation in the UN 2030 agenda, *Technol. Forecast. Soc. Change*, 2020, **154**, 119957.
 - 36 T. Bennich, S. Belyazid, I. Stjernquist, A. Diemer, S. Seifollahi-Aghmiuni and Z. Kalantari, The bio-based economy, 2030 Agenda, and strong sustainability – a regional-scale assessment of sustainability goal interactions, *J. Clean. Prod.*, 2021, **283**, 125174.



- 37 I. A. Baste and R. T. Watson, Tackling the climate, biodiversity and pollution emergencies by making peace with nature 50 years after the Stockholm Conference, *Glob. Environ. Change*, 2022, **73**, 102466.
- 38 M. Rosental, T. Fröhlich and A. Liebich, Life cycle assessment of carbon capture and utilization for the production of large volume organic chemicals, *Front. Clim.*, 2020, **2**, 586199.
- 39 X. Liu, A. Elgowainy and M. Wang, Life cycle energy use and greenhouse gas emissions of ammonia production from renewable resources and industrial by-products, *Green Chem.*, 2020, **22**(17), 5751–5761.
- 40 Y. Bicer, I. Dincer, C. Zamfirescu, G. Vezina and F. Raso, Comparative life cycle assessment of various ammonia production methods, *J. Clean. Prod.*, 2016, **135**, 1379–1395.
- 41 K. Shulla, W. Leal Filho, S. Lardjane, J. H. Sommer, A. L. Salvia and C. Borgemeister, The contribution of Regional Centers of Expertise for the implementation of the 2030 Agenda for Sustainable Development, *J. Clean. Prod.*, 2019, **237**, 117809.
- 42 V. Kyriakou, I. Garagounis, E. Vasileiou, A. Vourros and M. Stoukides, Progress in the Electrochemical Synthesis of Ammonia, *Catal. Today*, 2017, **286**, 2–13.
- 43 J. Humphreys, R. Lan and S. Tao, Development and Recent Progress on Ammonia Synthesis Catalysts for Haber–Bosch Process, *Adv. Energy Sustain. Res.*, 2021, **2**, 2000043.
- 44 G. R. Maxwell, Ammonia Synthesis, *Synthetic Nitrogen Products*, 2005, pp. 163–198, DOI: [10.1007/0-306-48639-3_6](https://doi.org/10.1007/0-306-48639-3_6).
- 45 Ž. Ponikvar, B. Likozar and S. Gyergyek, Electrification of Catalytic Ammonia Production and Decomposition Reactions: From Resistance, Induction, and Dielectric Reactor Heating to Electrolysis, *ACS Appl. Energy Mater.*, 2022, **5**, 5457–5472.
- 46 H. Shen, C. Choi, J. Masa, X. Li, J. Qiu, Y. Jung and Z. Sun, Electrochemical ammonia synthesis: mechanistic understanding and catalyst design, *Chem*, 2021, **7**, 1708–1754.
- 47 C. MacLaughlin, Role for Standardization in Electrocatalytic Ammonia Synthesis: A Conversation with Leo Liu, Lauren Greenlee, and Douglas MacFarlane, *ACS Energy Lett.*, 2019, **4**, 1432–1436.
- 48 C. A. Fernández, O. Chapman, M. A. Brown, C. E. Alvarez-Pugliese and M. C. Hatzell, Achieving Decentralized, Electrified, and Decarbonized Ammonia Production, *Environ. Sci. Technol.*, 2024, **58**, 21.
- 49 H. Zhang, L. Wang, J. Van herle, F. Maréchal and U. Desideri, Techno-economic comparison of green ammonia production processes, *Appl. Energy*, 2020, **259**, 114135.
- 50 H. Nami, P. V. Hendriksen and H. L. Frandsen, Green ammonia production using current and emerging electrolysis technologies, *Renew. Sustain. Energy Rev.*, 2024, **199**, 114517.
- 51 A. Dechany, K. Van Geem and J. Proost, Process implications of electrifying ammonia production, *Curr. Opin. Chem. Eng.*, 2023, **40**, 100915.
- 52 B. M. Comer, P. Fuentes, C. O. Dimkpa, Y. H. Liu, C. A. Fernandez, P. Arora and A. J. Medford, Prospects and Challenges for Solar Fertilizers, *Joule*, 2019, **3**, 1578–1605.
- 53 D. M. Miller, M. J. Liu, K. Abels, A. Kogler, K. S. Williams and W. A. Tarpeh, Engineering a molecular electrocatalytic system for energy-efficient ammonia production from wastewater nitrate, *Energy Environ. Sci.*, 2024, **17**, 5691–5705.
- 54 X. Fu, J. Zhang and Y. Kang, Recent advances and challenges of electrochemical ammonia synthesis, *Chem Catal.*, 2022, **2**, 2590–2613.
- 55 C. Chen, Y. Lu and R. Banares-Alcantara, Direct and indirect electrification of chemical industry using methanol production as a case study, *Appl. Energy*, 2019, **243**, 71–90.
- 56 Z. Mekidiche, J. A. Labarta, J. Javaloyes-Anton and J. A. Caballero, From power to heat: strategies for electrifying distillation for sustainable chemical processes, *Appl. Therm. Eng.*, 2024, **257**, 124316.
- 57 C. Cui, M. Qi, X. Zhang, J. Sun, Q. Li, A. A. Kiss and M. Lee, Electrification of distillation for decarbonization: an overview and perspective, *Renew. Sustain. Energy Rev.*, 2024, **199**, 114522.
- 58 C. Chen, Y. Lu and R. Banares-Alcantara, Direct and indirect electrification of chemical industry using methanol production as a case study, *Appl. Energy*, 2019, **243**, 71–90.
- 59 E. Díez, P. Langston, G. Ovejero and M. D. Romero, Economic feasibility of heat pumps in distillation to reduce energy use, *Appl. Therm. Eng.*, 2009, **29**, 1216–1223.
- 60 C. Cui, X. Zhang, M. Qi, H. Lyu, J. Sun and A. A. Kiss, Fully electrified heat pump assisted distillation process by flash vapour circulation, *Chem. Eng. Res. Des.*, 2024, **206**, 280–284.
- 61 A. A. Kiss and R. Smith, Rethinking energy use in distillation processes for a more sustainable chemical industry, *Energy*, 2020, **203**, 117788.
- 62 T. Wu, C. Wang, J. Liu, Y. Zhuang and J. Du, Design and 4E analysis of heat pump-assisted extractive distillation processes with preconcentration for recovering ethylacetate and ethanol from wastewater, *Chem. Eng. Res. Des.*, 2024, **201**, 510–522.
- 63 H. Wang, P. Yu, L. Chen, L. Chen and B. Sun, Simulation and modification of an ethane-ethylene separation unit using vapor recompression heat pump: energy, exergy, and economic analyses, *Appl. Therm. Eng.*, 2024, **239**, 121993.
- 64 M. Qi, X. Zhang, D. S. H. Wong, C. M. Shu, C. Cui and A. A. Kiss, Electrified distillation with flash vapor circulation and thermal storage for dynamic electricity markets, *AIChE J.*, 2025, **71**, e18750.
- 65 A. K. Jana, Advances in heat pump assisted distillation column: a review, *Energy Convers. Manag.*, 2014, **77**, 287–297.
- 66 M. Lou, X. Zhu, X. Fang, Y. Liu and F. Li, Interception of volatile organic compounds through CNT



- electrochemistry of electrified membrane surface during membrane distillation, *Sep. Purif. Technol.*, 2022, **297**, 121380.
- 67 C. Cui, N. V. D. Long, J. Sun and M. Lee, Electrical-driven self-heat recuperative pressure-swing azeotropic distillation to minimize process cost and CO₂ emission: process electrification and simultaneous optimization, *Energy*, 2020, **195**, 116998.
- 68 BASF Press Release, <https://www.basf.com/global/en/media/news-releases/2024/04/p-24-173.html>.
- 69 S&P Global Commodity Insights, <https://www.spglobal.com/commodityinsights/en/market-insights/latest-news/energy-transition/061024-yara-starts-up-europes-largest-green-hydrogen-plant-in-norway>.
- 70 Fertiberia Official Site, <https://www.fertiberia.com/en/what-we-do/green-hydrogen-and-low-carbon-ammonia/>.
- 71 A. Kalair, N. Abas, M. S. Saleem, A. R. Kalair and N. Khan, Role of energy storage systems in energy transition from fossil fuels to renewables, *Energy Storage*, 2021, **3**, e135.
- 72 G. N. Psarros and S. A. Papathanassiou, Electricity storage requirements to support the transition towards high renewable penetration levels—application to the Greek power system, *J. Energy Storage*, 2022, **55**, 105748.
- 73 P. Poizot and F. Dolhem, Clean energy new deal for a sustainable world: from non-CO₂ generating energy sources to greener electrochemical storage devices, *Energy Environ. Sci.*, 2011, **4**, 2003–2019.
- 74 L. Göke, J. Weibezahn and M. Kendzioriski, How flexible electrification can integrate fluctuating renewables, *Energy*, 2023, **278**, 127832.
- 75 W. Meng, D. Wang, H. Zhou, Z. Liao, X. Hong and G. Li, Design and analysis for chemical process electrification based on renewable electricity: coal-to-methanol process as a case study, *Energy Convers. Manag.*, 2023, **292**, 117424.
- 76 R. M. Johannsen, B. V. Mathiesen, K. Kermeli, W. Crijns-Graus and P. A. Østergaard, Exploring pathways to 100% renewable energy in European industry, *Energy*, 2023, **268**, 126687.
- 77 O. Ellabban, H. Abu-Rub and F. Blaabjerg, Renewable energy resources: current status, future prospects and their enabling technology, *Renew. Sustain. Energy Rev.*, 2014, **39**, 748–764.
- 78 A. Toktarova, L. Göransson and F. Johnsson, Electrification of the energy-intensive basic materials industry – implications for the European electricity system, *Int. J. Hydrogen Energy*, 2025, **107**, 279–295.
- 79 H. Choi, J. Shin, C. Yeon, S. Y. Park, S. T. Bae, J. W. Kim and H. J. Chang, Unveiling the high-temperature degradation mechanism of solid oxide electrolysis cells through direct imaging of nanoscale interfacial phenomena, *Energy Environ. Sci.*, 2024, **17**(15), 5410–5420.
- 80 Y. Wang, W. Li, L. Ma, W. Li and X. Liu, Degradation of solid oxide electrolysis cells: phenomena, mechanisms, and emerging mitigation strategies—a review, *J. Mater. Sci. Technol.*, 2020, **55**, 35–55.
- 81 C. Philibert, Direct and indirect electrification of industry and beyond, *Oxf. Rev. Econ. Policy*, 2019, **35**, 197–217.
- 82 D. Kassem, Does electrification cause industrial development? Grid expansion and firm turnover in Indonesia, *J. Dev. Econ.*, 2024, **167**, 103234.
- 83 C. M. Masuku, R. S. Caulkins and J. J. Sirola, Process decarbonization through electrification, *Curr. Opin. Chem. Eng.*, 2024, **44**, 101011.
- 84 A. Ashabi, M. Mostafa, A. Hryshchenko, K. Bruton and D. T. J. O'sullivan, Assessing power-to-heat technologies for industrial electrification: a multi-criteria decision analysis approach, *Energy Convers. Manage.: X*, 2025, **25**, 100882.
- 85 H. Chen and Y. Wang, Can electrification mitigate the marginal cost of carbon emission abatement? Evidence from China, *Util. Policy*, 2025, **93**, 101883.
- 86 S. Banerjee, Energy Storage to Decarbonize the Industrial Sector Through Direct Electrification, *Energy Storage for Manufacturing and Industrial Decarbonization Workshop*.
- 87 T. Caetano, H. Winker and J. Depledge, Towards zero carbon and zero poverty: integrating national climate change mitigation and sustainable development goals, *Clim. Policy*, 2020, **20**, 773–778.
- 88 S. G. Nnabuife, E. Oko, B. Kuang, A. Bello, A. P. Onwualu, S. Oyagha and J. Whidborne, The prospects of hydrogen in achieving net zero emissions by 2050: a critical review, *Sustain. Chem. Clim. Action*, 2023, **2**, 100024.
- 89 V. L. Trinh and C. K. Chung, Renewable energy for SDG-7 and sustainable electrical production, integration, industrial application, and globalization: review, *Clean Eng. Technol.*, 2023, **15**, 100657.
- 90 Accenture, *Decarbonizing Europe's chemical industry: costs and opportunities under the EU Green Deal*, 2022, <https://www.accenture.com/content/dam/accenture/final/a-com-migration/r3-3/pdf/pdf-174/accenture-chemicals-costs-opportunities-eu-green-deal.pdf>.
- 91 Financial Times, *What is needed for hydrogen to really take off*, Financial Times, 2023, <https://www.ft.com/partnercontent/kawasaki-heavy-industries/what-is-needed-for-hydrogen-to-really-take-off.html>.
- 92 Financial Times, *US tax incentives for green hydrogen under review*, Financial Times, 2023, <https://www.ft.com/content/60f1e1c4-731f-43dd-ba01-d2da206bec4d>.
- 93 K. M. Adamson, T. G. Walmsley, J. K. Carson, Q. Chen, F. Schlosser, L. Kong, D. J. Cleland, *et al.*, High-temperature and transcritical heat pump cycles and advancements: a review, *Renew. Sustain. Energy Rev.*, 2022, **167**, 112798.
- 94 D. S. Mallapragada, Y. Dvorkin, M. A. Modestino, D. V. Esposito, W. A. Smith, B. M. Hodge and A. D. Taylor, Decarbonization of the chemical industry through electrification: barriers and opportunities, *Joule*, 2023, **7**, 23–41.
- 95 International Energy Agency, *The Future of Petrochemicals Towards More Sustainable Plastics and Fertilisers Together Secure Sustainable*, 2018, <https://www.iea.org/t&c/>.
- 96 J. Hess, D. Bednarz, J. Bae and J. Pierce, Petroleum and Health Care: Evaluating and Managing Health Care's



- Vulnerability to Petroleum Supply Shifts, *Am. J. Publ. Health*, 2011, **101**, 1568.
- 97 B. Akbas, A. S. Kocaman, D. Nock and P. A. Trotter, Rural electrification: an overview of optimization methods, *Renew. Sustain. Energy Rev.*, 2022, **156**, 111935.
- 98 J. Gallegos, P. Arévalo, C. Montaleza and F. Jurado, Sustainable Electrification—Advances and Challenges in Electrical-Distribution Networks: A Review, *Sustainability*, 2024, **16**, 698.
- 99 P. Sorknæs, R. M. Johannsen, A. D. Korberg, T. B. Nielsen, U. R. Petersen and B. V. Mathiesen, Electrification of the industrial sector in 100% renewable energy scenarios, *Energy*, 2022, **254**, 124339.
- 100 X. Li, D. Lepour, F. Heymann and F. Maréchal, Electrification and digitalization effects on sectoral energy demand and consumption: a prospective study towards 2050, *Energy*, 2023, **279**, 127992.
- 101 K. Abouemara, M. Shahbaz, G. Mckay and T. Al-Ansari, The review of power generation from integrated biomass gasification and solid oxide fuel cells: current status and future directions, *Fuel*, 2024, **360**, 130511.
- 102 K. M. Van Geem and B. M. Weckhuysen, Toward an e-chemistree: materials for electrification of the chemical industry, *MRS Bull.*, 2021, **46**, 1187–1196.

