

Concluding remarks: Directing and controlling materials and molecules

Graham R. Fleming  abc

Received 30th June 2022, Accepted 13th July 2022

DOI: 10.1039/d2fd00133k

Controlling the macroscopic properties of materials, particularly quantum materials, *via* external inputs such as optical fields is a key goal of modern physical science. The *Faraday Discussion* presented a cross section of current experimental and theoretical progress with mostly ultrashort pulse excitations with frequencies ranging from the X-ray to the THz regions of the spectrum. This paper offers a perspective on the meaning of control in different scientific and engineering contexts. Despite the enormous challenge of implementing full feedback control on the types of material of interest in this discussion, I sketch such a system taken from a photosynthetic context to provide inspiration for future development in control of materials.

1. Introduction

The word control or controlling has appeared only three times in the titles of *Faraday Discussions* over the past 25 years, in 1999, 2011 and 2022. For example, the 2011 discussion on Coherence and Control in Chemistry used the term to describe the use of ultrashort light pulses and/or interference effects to modify photochemical reaction yields in “Coherent Control.” This discussion appears to be the first confronting control of materials, no doubt indicating the difficulty of such control. Nonetheless the control of material and molecular properties, and responses, by external means such as by using ultrashort optical or THz pulses, is a major goal of condensed phase physical science.^{1,2} One stimulus for this focus is in a 15 year old report for the Basic Energy Sciences Division of the Office of Science of the U.S. Department of Energy.¹ The report in 2007 put forth the view with respect to materials and molecular systems that we were at the threshold of a transformation to “control science” and noted that new tools would be required to achieve this transition, in particular tools that provide multimodal information on the timescales of quasi particles, electrons, and nuclear motions, on the length scale of bond lengths, defects, and lattice spacing, and with an energy resolution on a scale appropriate to the specific system under study. The papers in this

^aDepartment of Chemistry, University of California, Berkeley, USA. E-mail: grfleming@lbl.gov

^bMolecular Biophysics and Integrated Bioimaging Division, Lawrence Berkeley National Laboratory, USA

^cKavli Energy NanoScience Institute, Berkeley, CA 94720, USA



discussion build on advances in creating attosecond and femtosecond light sources from X-ray to THz frequencies, and on advances in microscopies such as electron microscopy. However, rather less progress has been made in methods that combine both temporal and spatial dimensions. Significant progress has also been made in theoretical methods, though many problems remain in electron-correlated systems.³

The report cited above shied away from using controlling in its title, settling instead for “Directing Matter and Energy: Five Challenges for Science and the Imagination.” The five challenges are:

- How do we control materials and processes at the level of electrons?
- How do we design and perfect atom- and energy-efficient synthesis of new forms of matter with tailored properties?
- How do remarkable properties of matter emerge from complex correlations of atomic and electronic constituents and how can we control these properties?
- Can we master energy and information on the nanoscale to create new technologies with capabilities rivaling those of living systems?
- How do we characterize and control matter away—especially very far away—from equilibrium?

A follow-on report in 2015 described progress on the five “Grand Challenges” and the challenges and opportunities for continued progress towards true control of matter and energy.² The challenges listed above are daunting but, aside from the fourth challenge, they map directly onto the topics described in four sessions of this discussion.

In the context of this discussion ultrashort light pulses play a key role in most of the directing and controlling topics discussed. Perhaps the most apparent control method is to use the ultrahigh time resolution to outpace interfering phenomena, such as decoherence when coherence is required for the desired output. The development of optical pulses across the optical spectrum enables nonlinear, generally third-order spectroscopies, which probe the system response to intense applied electric and magnetic fields. Such studies, in particular multi-dimensional coherent spectroscopies, have dramatically changed our ability to study complex, often partly disordered, material and molecular systems. However, except in rare cases these nonlinear spectroscopies do not provide complementary spatial information. As Burghardt *et al.* (<https://doi.org/10.1039/D2FD00014H>) described in their contribution higher order spectroscopies such as fifth order responses, *via* interaction between elementary excitations (*e.g.* excitons), have the potential to provide complementary spatial input into the dynamics of extended systems. Such a program will require the fifth-order signal to be cleanly separated from both lower and higher order responses. The intense electric and magnetic fields of ultrashort pulses also enable the application of non-thermal effects such as modification of the system’s potential energy surface to allow, for example, the creation of phases that are not accessible thermally. Non-thermal pathways created by ultrashort light pulses to control the macroscopic properties of quantum materials have recently been discussed in detail by de la Torre *et al.*⁴ from which Fig. 1 is taken. Optical switching into metastable states, for example, can enable new applications to low temperature memories or to microelectronics.⁴

Turning to molecular systems two papers – Kim, Castellano, Li, Chen *et al.* (<https://doi.org/10.1039/D2FD00009A>), and McCusker *et al.* (<https://doi.org/>



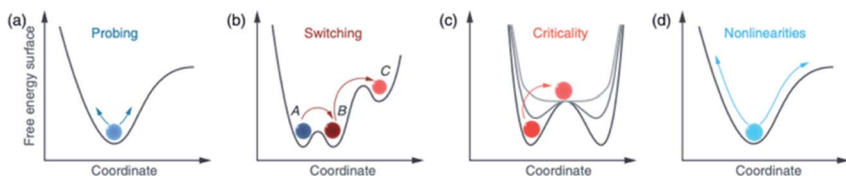

Fig. 1 Illustration of the range of applications of increasingly intense short light pulses to material systems. (a) Probing quasi particle interactions. (b) A more intense pulse populates the degenerate g.s. or moves the system to a metastable state. (c) Modifying the PES to induce nonequilibrium critical behavior. (d) Moving out of the harmonic region to create nonlinearities. (Figure reprinted with permission from A. De La Torre, D. M. Kennes, M. Claassen, S. Gerber, J. W. McIver and M. A. Sentef, *Rev. Mod. Phys.*, 2021, **93**, 041002. Copyright 2021 by the American Physical Society).⁴

10.1039/D2FD00106C) – take up the question of whether vibrational or vibronic wavepackets generated by ultrashort pulses can provide insights to guide synthetic control of photochemical reaction pathways – a long-standing goal of chemistry. Distinguishing spectator modes from modes directly involved in the dynamics remains highly challenging and system specific. As yet no general rules have emerged, though in one case modification of the structure with the goal of attenuating and perhaps decoupling a specific large amplitude motion from the reaction coordinate had the predicted effect of slowing the dynamics (McCusker *et al.*, <https://doi.org/10.1039/D2FD00106C>). The analysis of vibronic interactions in two-dimensional electronic spectra (2DES) of excitonic systems by Burghardt *et al.* (<https://doi.org/10.1039/D2FD00014H>) suggests that specific excitation of low frequency (“soft”) modes could be used to optimize transport properties *via* the control of dynamical disorder to guide quasi-particle motion.

2. Directing and controlling

The word control or controlling carries differing meanings in different communities. To an engineer, control aimed at improving stability, robustness, and performance involves closed loop feedback systems. A familiar example is cruise control to keep the speed of a vehicle steady at a set value. The Shorter Oxford English Dictionary gives two main meanings for control: (1) the act or power of directing or regulating and (2) the action of holding in check or prevention of something unwanted. The papers in this discussion use the first definition, in other words to make something happen that would not happen spontaneously, for example, thermally. Examples are a quantum phase change or a translocation of an atom or group from one location to another. “Photodoping”, transient n-type doping of a semiconductor by optical excitation of deep electronic defects, as described by Gierster *et al.* (<https://doi.org/10.1039/D2FD00036A>), raises the possibility of transient control of material properties, such as conductivity in practical devices. The second meaning of control, implying that a material or system can limit the extent of a change in response to rapid changes in external parameters to optimize (smooth) output or minimize damage is obviously far more challenging. Such control, however, can be met in some cases by passive design rather than active feedback. For example, Arp *et al.*⁵ use



a network model to show that the absorption spectra of natural photosynthetic light harvesting systems from a variety of organisms adapted to widely differing light conditions (e.g. full sunlight, filtered by seawater, or other organisms), and with different sets of absorber molecules, minimize the sensitivity of the output to fluctuations in light level. The model is based on spectral separation of two (groups of) absorbers with appropriate wavelength separation and reproduces the actual spectra of plant and bacterial antenna systems. As will be discussed briefly below, to minimize oxidative damage from excess light (a daily occurrence for plants and algae) feedback systems more directly resembling the engineering control loops described above are utilized for photoprotection by land plants and algae. Control theory and application in the engineering sense has been extensively discussed in a domain intermediate between materials and natural systems – that of synthetic biology.^{6,7}

What phenomena are of most interest for control or prevention in materials in which delicate quantum phenomena such as conventional and unconventional superconductivity occur, or in quantum information/computing systems? Coherence destroying processes such as electron scattering, or spin-lattice relaxation should be outrun or minimized. The very high electric fields and few-cycle duration pulses now available with THz sources bring new opportunities, several of which were harnessed in this discussion. For example, Iwai *et al.* (<https://doi.org/10.1039/D2FD00004K>) avoid the generation of quasi particles which lead to an increase in electron temperature and destroy electronic coherence by using 6 fs THz pulses to create synchronized coherent charge oscillation and a scattering-free current, on a timescale faster than that of electron scattering, in an organic superconductor. The scattering-free current had previously been hidden by the increase in electron temperature and the enhancements of the nonlinear optical response towards T_{SC} suggest a relationship to T_{SC} and/or superconducting fluctuations. Udina *et al.* (<https://doi.org/10.1039/D2FD00016D>) note that the nonlinear Raman responses to THz pulses and to visible pulses are not equal so that excitation of collective modes of e.g. the superconducting order parameter, requires sophisticated methods to interpret experimental data.

Overall, the discussion provided a view of a rapidly developing field where new light sources such as free electron lasers, lab-based XUV and THz sources are being applied to highly complex materials, where even the nature of the measured quantity is not fully clear in some cases. What is clear, however, is that enormous technological advances could be realized with the ability to control quantum materials *via* external, non-thermal means. Similarly, the ability to design or exploit vibronic coherence for control of photochemical dynamics could also have far reaching applications. The development of experimental methods capable of removing obscuring signals such as those from heating, is rapidly emerging in both optical and THz spectroscopies.

3. Looking forward

New light sources, particularly in the X-ray and XUV regions, will create new opportunities.⁸ High repetition-rate sources will enable mapping of charge distributions and reaction dynamics on the molecular length scale. They should enable element specific mapping of quantum coherences, and multidimensional



spectroscopies in the soft and hard X-ray regions and perhaps two-color (hard-soft) two-dimensional spectroscopy. Time resolved X-ray scattering will go some way to filling the needs for combined spatial and temporal resolution.

New light sources hold great promise for the study of quantum materials, *via* resonant inelastic X-ray scattering, for example. The spontaneous fluctuations and nanoscale heterogeneity typical of strongly correlated materials with multiple phases can be addressed with X-ray photon correlation spectroscopy with chemical specificity, for example.

The methods alluded to above likely require facility-level free electron laser systems to produce highly intense sources. There is a second area utilizing much weaker sources – quantum light spectroscopy based on single photon pairs. Single photon pairs, which may or may not be quantum mechanically entangled in *e.g.* polarization, or frequency, enable a great number of new control parameters. Examples are entanglement time, joint spectra, different frequencies between the pairs, *etc.*⁹ Frequency–time entangled pairs can break the Fourier transform limit of simultaneous temporal and spectral resolution. In other words, resolution of highly congested spectra with very rapid relaxation timescales should become possible. For imaging, quantum light provides the potential for:

- Sub shot noise measurement microscopy
- Low intensity non-linear imaging of fragile systems
- Imaging with one wavelength and detecting at another wavelength (*e.g.* to reduce scattering or detect at a wavelength with more sensitive detectors)
- Imaging without illuminating the sample
- Counting biomolecules for improved localization
- Enhanced resolution in super-resolution microscopy by photon statistics
- Entangled electron pair microscopy

The final bullet point deals not with photons but with entangled electrons which could alleviate the sample damage problems of conventional electron microscopy.

For dynamical studies single photon pairs offer the following tantalizing possibilities:

- Photon statistics to characterize quantum *vs.* classical dynamics
- High time and spectral resolution
- High time and spatial resolution
- Linear two-photon absorption
- New molecular control strategies
- Exploring polariton bio-chemistry (molecular cavities)

In addition many possibilities can be imagined by combining a classical pulse with an entangled photon pair.⁹

Much initial interest centered on the possibility of using single photon pairs to carry out two photon absorption that is linear in photon number for microscopy. Currently this remains a controversial topic¹⁰ but new sources such as bright squeezed vacuums, may change the picture in the future. The possibility of using the quantum state of light as a parameter for the coherent control of material properties was described theoretically by Ishida *et al.* (<https://doi.org/10.1039/D2FD00007E>). The application of such selected states, for example, length squeezed vacuums, provides a tantalizing glance of future possibilities.

From a practical application perspective, femtosecond lasers, let alone free electron lasers, are unlikely to produce a scalable technology. Real world devices



will likely use sunlight directly or indirectly *via* electricity as their energy input. If the device uses sunlight directly this brings up a question which has been raised in studies of photosynthesis: are the coherences observed with femtosecond light sources relevant to actual photosynthesis in sunlight (an incoherent thermal source)? We have recently demonstrated using quantum light that a photosynthetic cycle of absorption, energy transfer to different absorbers, multiple more energy transfer steps and finally emission of fluorescence starts and proceeds at the single quantum level. Although questions remain about the spatio-temporal nature of the initial excitation, this result strongly implies that yes, the ultrafast spectroscopic results are directly applicable to systems in sunlight. Such a picture will also apply to material systems.

4. Towards full control

The fourth “Grand Challenge” listed in the introduction suggests looking to the biosphere for inspiration for what is possible in full control of materials. With the goal of provoking consideration of application of feedback control to optimize output, minimize damage *etc.* I provide a brief description of the type of control system used by land plants and algae.

To operate the only TW energy conversion system on earth, which is intrinsically and necessarily a nanoscale system,¹¹ plants and algae must balance two contradictory requirements. For optimal efficiency through the diurnal cycle hundreds of antenna molecules (mostly chlorophylls) surround a reaction center that initiates charge separation, the first chemical event of photosynthesis.¹² To provide excitation energy to the reaction center, the exciton must move hundreds of times with each step very much faster than any dissipation timescale in the

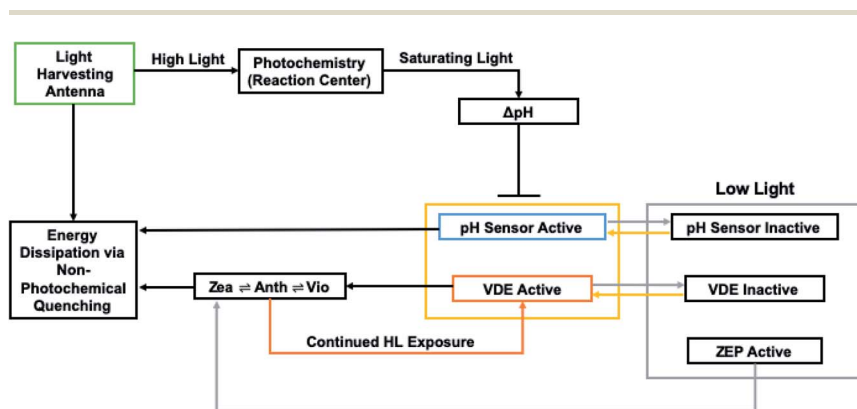

Fig. 2 A schematic of the dual roles of light harvesting antennae, which switch between energy harvesting (photochemistry) and energy dissipation (non-photochemical quenching) based on the light levels. When the reaction centers (RC) are saturated, energy must be dissipated quickly before reactive oxygen species can form. Normal action of photosystem II leads to a pH-gradient forming across the thylakoid membrane; but when excess light is present and the internal pH drops below a fixed value, pH sensitive proteins are triggered. Violaxanthin de-epoxidase (VDE) is one of these pH-activated proteins that acts as an actuator (orange box), regulating the amount of Zea to efficiently dissipate excess energy. When low light conditions return (grey box), VDE is inactivated, and zeaxanthin epoxidase (ZEP) reverses the conversion of Zea back to Vio.





Fig. 3 Fluorescence lifetime quenching (NPQ τ) traces for four irregular fluctuating light sequences in *N. oceanica* algal cells (A–D).¹³ The experimental NPQ τ (blue, open circles) and model predicted NPQ τ curves (red line) are shown. The black boxes at the bottom of each plot represent the dark periods while the white boxes represent HL exposure. Overall, the model is able to reproduce the rapid switch on/off with the transitions between light/dark and vice versa. 95% confidence intervals are represented by error bars ($n = 3$). (Data from A. H. Short, *et al.*, *J. Chem. Phys.*, 2022, **156**, 205102, Copyright 2022 Author(s) under a Creative Commons Attribution 4.0 license).

absorbers. On the other hand, overexcitation of the reaction center leads to the formation of reactive oxygen species including singlet oxygen which destroy the proteins holding the antenna molecules and reaction center components. All green photosynthetic organisms have developed a feedback scheme to respond to fluctuations in light level (from clouds, wind moving leaves above, waves in water producing transient lenses, *etc.*). A dissipation mechanism based on a sensor actuator feedback cycle is reversibly turned on in response to excess light and off in low light. The simplest feedback scheme we have found is in a micro alga called *Nannochloropsis oceanica* illustrated in Fig. 2.

Photosystem II of plants and algae generates protons (from water splitting) in the lumen (inner) compartment of the chloroplast and therefore a pH gradient across the photosynthetic membrane. Low lumen pH also activates an enzyme (the actuator) which converts one carotenoid (violaxanthin) to another (zeaxanthin). Zeaxanthin, likely in consort with the pH sensor protein, initiates dissipation of antenna excitations before they reach the reaction center. When the light level drops, the pH gradient dissipates and a second enzyme converts the zeaxanthin back to violaxanthin which does not produce quenching of excitation.

Fig. 3 shows the response of *N. oceanica* to varying periods of high light and dark along with a kinetic model of the feedback scheme sketched above.¹³ Being a “bottom up” model, the model makes predictions for the carotenoid



concentrations during such illumination sequences which are in reasonable accord with separate experimental measures of the predicted concentrations.

Although plants have more complex control systems,¹⁴ the elements described above are responsible for the rapid response of plants to excess light. As an important aside, optimizing this control system for crop plants will be important for food production by 2050 as population outpaces production, echoing the 1898 prediction of physicist William Crookes^{15,16} which led to the Haber–Bosch process and the development of ammonia-based fertilizers.

Can such sophisticated controls be applied to material systems? A simple pH reactive antenna system has been demonstrated.¹⁷ With soft materials passive control of temperature has been achieved.¹⁸ To continue this development, as ref. 2 notes, creating complexity and functionality will require coupling of chemical, optical, electronic, magnetic, mechanical and thermal degrees of freedom. The extraordinary possibilities imaginable for, *e.g.*, energy materials or even quantum materials provide an exciting vista for the future.

Conflicts of interest

There are no conflicts of interest to declare.

Acknowledgements

I am very grateful to Ms Audrey Short for providing Fig. 2 and 3 and Dr Collin Steen for helping me assemble the manuscript. I gratefully acknowledge support from the U.S. Department of Energy, Office of Science, Division of Basic Energy Sciences, Chemical Sciences, Geosciences and Biosciences Department *via* FWP 449A and 449B.

References

- 1 *Directing Matter and Energy: Five Challenges for Science and the Imagination*, <https://www.osti.gov/servlets/purl/935427>, 2007, DOI: [10.2172/935427](https://doi.org/10.2172/935427).
- 2 *Challenges at the Frontiers of Matter and Energy: Transformative Opportunities for Discovery Science*, <https://www.osti.gov/servlets/purl/1283188>, 2015, DOI: [10.2172/1283188](https://doi.org/10.2172/1283188).
- 3 A. Alexandradinata, N. P. Armitage, A. Baydin, W. Bi, Y. Cao, H. J. Changlani, E. Chertkov, E. H. da S. Neto, L. Delacretaz, I. El Baggari, G. M. Ferguson, W. J. Gannon, S. A. A. Ghorashi, B. H. Goodge, O. Goulko, G. Grissonnanche, A. Hallas, I. M. Hayes, Y. He, E. W. Huang, A. Kogar, D. Kumah, J. Y. Lee, A. Legros, F. Mahmood, Y. Maximenko, N. Pellatz, H. Polshyn, T. Sarkar, A. Scheie, K. L. Seyler, Z. Shi, B. Skinner, L. Steinke, K. Thirunavukkuarasu, T. V. Trevisan, M. Vogl, P. A. Volkov, Y. Wang, Y. Wang, D. Wei, K. Wei, S. Yang, X. Zhang, Y.-H. Zhang, L. Zhao and A. Zong, 2020, arXiv:10.48550/arxiv.2010.00584.
- 4 A. De La Torre, D. M. Kennes, M. Claassen, S. Gerber, J. W. McIver and M. A. Sentef, *Rev. Mod. Phys.*, 2021, **93**, 041002.
- 5 T. B. Arp, J. Kistner-Morris, V. Aji, R. J. Cogdell, R. Van Grondelle and N. M. Gabor, *Science*, 2020, **368**, 1490–1495.
- 6 D. Del Vecchio, A. J. Dy and Y. Qian, *J. R. Soc. Interface*, 2016, **13**, 20160380.



- 7 V. Hsiao, A. Swaminathan and R. M. Murray, *IEEE Control Syst*, 2018, **38**, 32–62.
- 8 *New Science Opportunities Enabled by LCLS-II X-Ray Lasers*, <https://www.osti.gov/servlets/purl/1630267>, 2015, DOI: **10.2172/1630267**.
- 9 K. E. Dorfman, F. Schlawin and S. Mukamel, *Rev. Mod. Phys.*, 2016, **88**, 045008.
- 10 A. Mikhaylov, R. N. Wilson, K. M. Parzuchowski, M. D. Mazurek, C. H. Camp, M. J. Stevens and R. Jimenez, *J. Phys. Chem. Lett.*, 2022, **13**, 1489–1493.
- 11 E. Edri, S. Aloni and H. Frei, *ACS Nano*, 2018, **12**, 533–541.
- 12 R. E. Blankenship, *Molecular Mechanisms of Photosynthesis*, Wiley, Chichester, 3rd edn, 2021.
- 13 A. H. Short, T. P. Fay, T. Crisanto, J. Hall, C. J. Steen, K. K. Niyogi, D. T. Limmer and G. R. Fleming, *J. Chem. Phys.*, 2022, **156**, 205102.
- 14 J. Zaks, K. Amarnath, D. M. Kramer, K. K. Niyogi and G. R. Fleming, *Proc. Natl. Acad. Sci. U. S. A.*, 2012, **109**, 15757–15762.
- 15 W. Crookes, *Science*, 1898, **8**, 561–575.
- 16 P. Horton, S. P. Long, P. Smith, S. A. Banwart and D. J. Beerling, *Nat. Plants*, 2021, **7**, 250–255.
- 17 Y. Terazono, G. Kodis, K. Bhushan, J. Zaks, C. Madden, A. L. Moore, T. A. Moore, G. R. Fleming and D. Gust, *J. Am. Chem. Soc.*, 2011, **133**, 2916–2922.
- 18 X. He, M. Aizenberg, O. Kuksenok, L. D. Zarzar, A. Shastri, A. C. Balazs and J. Aizenberg, *Nature*, 2012, **487**, 214–218.

