

Green Chemistry

Accepted Manuscript



This is an *Accepted Manuscript*, which has been through the Royal Society of Chemistry peer review process and has been accepted for publication.

Accepted Manuscripts are published online shortly after acceptance, before technical editing, formatting and proof reading. Using this free service, authors can make their results available to the community, in citable form, before we publish the edited article. We will replace this *Accepted Manuscript* with the edited and formatted *Advance Article* as soon as it is available.

You can find more information about *Accepted Manuscripts* in the [Information for Authors](#).

Please note that technical editing may introduce minor changes to the text and/or graphics, which may alter content. The journal's standard [Terms & Conditions](#) and the [Ethical guidelines](#) still apply. In no event shall the Royal Society of Chemistry be held responsible for any errors or omissions in this *Accepted Manuscript* or any consequences arising from the use of any information it contains.



www.rsc.org/greenchem



Green Chemistry

COMMUNICATION

Oxidative conversion of glucose to gluconic acid by iron (III) chloride in water under mild conditions

Hongdan Zhang,^{a,b,c} Ning Li,^b Xuejun Pan,^{b,*} Shubin Wu^{c,*} and Jun Xie^a

A simple method was demonstrated to oxidize glucose to gluconic acid in concentrated FeCl₃ solution. The maximum gluconic acid yield (52.3%) was achieved in 40% FeCl₃ solution at 110 °C in 4 hour. Formic and acetic acids were main coproducts with a yield of 10-20%.

In response to the inevitable depletion of fossil resources and consequent environmental issues of fossil fuels consumption, more attention has been paid to the fuels and chemicals derived from renewable resources.^{1,2} Lignocellulosic biomass has been identified as an alternative resource for future fuels, chemicals, and materials because of its carbon-neutral nature, abundance, and renewability. Glucose, the hydrolysis product of cellulose (the most dominant component in lignocellulosic biomass), is an important platform chemical for producing biofuels and biochemicals, in addition to direct applications in many sectors.^{3,4}

Gluconic acid, a derivative of glucose, has been widely used in food and pharmaceutical industries.^{5,6} It can be produced from glucose by chemical, biochemical, bioelectrochemical, and electrochemical approaches.⁵ Currently, gluconic acid is commercially produced from glucose fermentation by fungi, such as *A. niger*.^{5,7} In consideration of long reaction time and high cost of the fermentation processes, many researchers have explored effective chemical-transformation methods to produce gluconic acid.⁶ For example, supported Au, Pt, and Pd were found to be effective heterogeneous catalysts under O₂ atmosphere to produce gluconic acid with high yield and selectivity. Gold nanoparticles on carbon nanotubes (Au/CNTs) could catalyze the oxidation of

cellobiose by O₂, yielding 80% gluconic acid at 145 °C.⁸ The alumina-supported gold catalyst showed high activity and selectivity in the continuous-flow glucose oxidation to gluconic acid.⁹ Sulfonated carbon supported Pt catalyst (Pt/C-SO₃H) also had good performance in converting cellobiose and starch to gluconic acid.¹⁰ Although these supported noble-metal catalysts achieved good yield of gluconic acid, high cost impeded their commercial application. In addition to oxygen, H₂O₂ was also used for the oxidation of glucose because of its reasonable price, safe storage, and low environmental impact. For example, glucose was oxidized to gluconic and formic acids with H₂O₂ coupled with hydrothermal electrolysis; however, the selectivity to gluconic acid was poor.¹¹ Recently, it was reported that glucose was efficiently and selectively oxidized to gluconic acid by H₂O₂ in the presence of FeSO₄ as catalyst under ultrasonic irradiation.¹²

Metal halides have been used in the conversion of carbohydrates to furans, organic acids, and polyols.^{13,14} For example, FeCl₃ was involved in many biomass conversion processes because of its unique properties such as nontoxicity, low-cost, abundance, and high selectivity.¹⁵ Zhang et al. developed a process to convert xylose, xylan, and corncob to furfural using FeCl₃ as catalyst, yielding 66.8-86.5% furfural.¹⁶ It is well known that FeCl₃ has not only strong acidity but also oxidative power ($E^{\circ} = 0.77$ V for Fe³⁺/Fe²⁺), and its oxidative power increases with concentration. However, so far, all the studies using FeCl₃ in biomass conversion focused on the acidity of FeCl₃, and little attention has been paid to the oxidative power of FeCl₃.

In this study, concentrated FeCl₃ was explored as an oxidizing agent to oxidize glucose to gluconic acid. The performance of FeCl₃ in oxidizing glucose to gluconic, formic, and acetic acids was assessed at varying concentrations (30-60% (w/w)), temperatures (100-120 °C), and reaction times (0.5-5 h). The effect of starting glucose concentration was also investigated on the yield and composition of the products. In addition, mechanisms of glucose oxidation by FeCl₃ to the organic acids were proposed and discussed.

^a Institute of New Energy and New Material, Key Laboratory of Energy Plants Resource and Utilization, Ministry of Agriculture, Key Laboratory of Biomass Energy of Guangdong Regular Higher Education Institutions, South China Agricultural University, Guangzhou 510642, P.R. China

^b Department of Biological Systems Engineering, University of Wisconsin-Madison, 460 Henry Mall, Madison, WI 53706, USA

^c State Key Laboratory of Pulp and Paper Engineering, South China University of Technology, Guangzhou 510640, P.R. China

Corresponding authors: Xuejun Pan, E-mail: xpan@wisc.edu, Tel.: +1 (608) 262-4951; Shubin Wu, E-mail: shubinwu@scut.edu.cn, Tel.: +86 (020) 22236808.

Electronic Supplementary Information (ESI) available: materials, experimental descriptions, analytical methods, and surface fitting with TableCurve 3D. See DOI: 10.1039/x0xx00000x

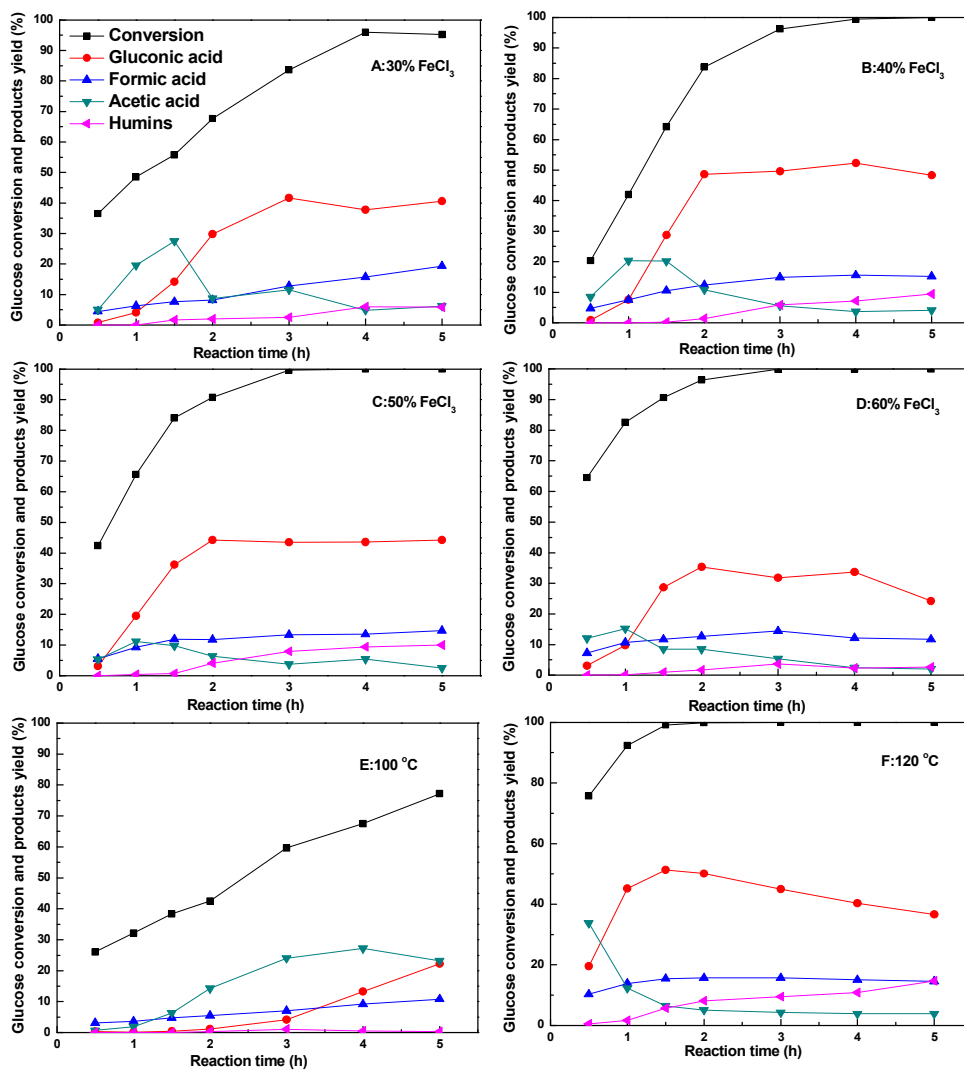

Fig. 1. Conversion of glucose and products yield at different FeCl₃ concentrations, reaction temperatures, and reaction times (Note: temperature in Figs. 1A-1D: 110 °C; FeCl₃ concentration in Figs. 1E and 1F: 40%; glucose concentration: 5%, w/v).

The conversion of glucose in FeCl₃ solution with varying concentrations, reaction times, and temperatures is presented in Fig. 1. As expected, the concentration of FeCl₃ solution had a significant effect on the glucose conversion and product selectivity. In general, the oxidative conversion yield and rate of glucose increased with the concentration of FeCl₃ solution. As shown in Fig. 1A, when the concentration of FeCl₃ was 30%, the conversion (consumption) of glucose increased from 36.5% to 83.6% from 0.5 to 3 h, and meanwhile the gluconic acid yields increased from 0.8% to 41.7%. Further extending reaction time to 4 or 5 h led to additional glucose conversion; however the yield of gluconic acid did not increase but decreased slightly, which could be ascribed to the degradation of gluconic acid and the formation of humins. To verify this, gluconic acid was treated in 40% FeCl₃ solution at 110 °C, it was found that 43.2% of gluconic acid was degraded/oxidized in 2 h, and formic acid was detected in the products, which was consistent with the observation above. It was reported that oxidation of glucose generated formic acid and acetic acid, in addition to gluconic acid.^{2,17,18} The same results were observed in this study. As shown in Fig. 1A, the yield of formic acid increased with reaction time and reached the maximal (19.4%) at 5 h. Differently, the yield of acetic acid reached to 27.5% quickly in 1.5 h and then declined to 4.9% at 4 h, which was probably caused by the oxidative decomposition of acetic acid^{19,20} and the formation of Fe(OAc)₂, as discussed in detail later. Similar results were observed at higher FeCl₃ concentrations (40%, 50%, and 60% in Figs. 1B, 1C, and 1D, respectively). These results suggested that extending reaction time was favorable to the decomposition of gluconic acid and acetic acid. It was also found that more humins were formed with extended reaction time.

When FeCl₃ concentration increased to 40%, gluconic acid yield reached 48.7% at 2 h and further increased to 52.3% at 4 h (Fig. 1B), which were higher than the yields (29.8% and 39.5%, respectively) obtained at 30% FeCl₃ (Fig. 1A) under the same reaction conditions. More concentrated FeCl₃ (50% and 60%) apparently oxidized glucose faster (Figs. 1C and 1D), but did not yield more gluconic acid (lower than 45% and 35%, respectively), which could be attributed to the oxidative degradation of gluconic acid. According to the Nernst equation, the oxidation potential increases with Fe³⁺ concentration. For example, the oxidation potential of Fe³⁺ increases approximately by 23.5 mV theoretically when FeCl₃ concentration increases from 30% to 60%. In addition, when glucose loading was the same (e.g. 5% w/v in Fig. 1), the ratio of Fe³⁺ to glucose increased with the FeCl₃ concentration. These results suggested that more concentrated FeCl₃ solution had stronger oxidative power, and 40% seemed to be an optimal FeCl₃ concentration to achieve high gluconic acid yield.

Temperature is a crucial variable in the oxidation of glucose to gluconic acid. Higher temperature accelerated the conversion, but promoted the undesired side reactions as well. The oxidation of glucose in 40% FeCl₃ at the temperatures of 100, 110, and 120 °C was compared, and the results are presented in Figs. 1E, 1B, and 1F, respectively. The temperatures used in this study were lower than that (145 °C) in the previous studies with supported noble-metal catalysts.^{8,20,21} As shown in Fig. 1E, glucose underwent a slower oxidation at 100 °C and reached a low conversion of 77.2% at 5 h, compared to the complete conversion (100%) at higher

temperatures in Figs. 1B (110 °C) and 1F (120 °C). The yield of gluconic acid was only 22.2% at 100 °C in 5 h. However, a large amount of acetic acid (up to 27.2%) was detected, suggesting that lower reaction temperature was favorable to acetic acid. When temperature was elevated to 110 °C (Fig. 1B), glucose was oxidized more rapidly, and gluconic acid yield reached a maximum yield within short reaction time, indicating that elevating temperature could significantly accelerate the reaction. The highest yield of gluconic acid (52.3%) was achieved at 4 h. When temperature was further raised to 120 °C (Fig. 1F), 100% glucose conversion was completed within 2 h. Gluconic acid yield reached 51.3% at 1.5 h and then decreased gradually when the reaction was extended because of the further oxidative degradation of gluconic acid, as shown in Fig. 2. Acetic acid reached the highest yield (33.8%) at 0.5 h and then decreased gradually. It was also observed that more humins formed at higher reaction temperature.

TableCurve 3D was used to determine the best fit for gluconic acid yield in relation to FeCl₃ concentration, reaction time, and reaction temperature, and the results are presented in Fig. S1 in Electronic Supplementary Information. The highest gluconic acid yield (52.3%) was predicted in 40% FeCl₃ solution at 110 °C in 2 hour.

The effect of glucose loading (starting concentration) on the oxidation of glucose to gluconic acid was examined as well. The effect of glucose concentration on gluconic acid yield was complicated. As shown in Table 1, the glucose conversion increased when glucose concentration increased, but glucose was not converted to the target acids but more humins. Surprisingly, only 3.2% gluconic acid was yielded at 2.5% glucose concentration. One possible reason was that the generated gluconic acid was further degraded by oxidation because the ratio of the oxidant (FeCl₃) to glucose was high at low glucose concentration. At 5% glucose concentration, the gluconic acid yield was the highest (48.7%). When glucose loading was further increased to 7.5%, 10%, and 20%, the gluconic acid yield reversely decreased sharply from 48.7% to 38.9%, 30.2%, and 13.9%, respectively, presumably because oxidant (FeCl₃) became insufficient when glucose loading was increased.

Table 1 Oxidation of glucose in 40% FeCl₃ at 110 °C in 2 h with different concentrations of glucose

Glucose Conc. (w/v, %)	Glucose conversion (%)	Product yield (%)			
		Gluconic acid	Formic acid	Acetic acid	Humins
2.5	81.7	3.2	11.0	20.9	0
5.0	83.8	48.7	12.3	10.8	1.4
7.5	94.0	38.9	12.3	5.3	12.6
10	96.8	30.2	12.4	9.9	17.9
20	97.2	13.9	11.0	4.3	29.2

The results in Table 1 suggested that 5% glucose concentration was optimal for gluconic acid in the range investigated. The yield of formic acid was independent of glucose concentration. However, the yield of acetic acid was greatly affected by glucose concentration. The highest acetic acid yield (20.9%) was obtained at the lowest glucose concentration (2.5%). Increasing glucose concentration resulted in lower acetic acid yield.

From the results and observations above, oxidation pathways of glucose to gluconic acid, formic acid, and acetic acid by FeCl_3 are proposed and presented in Fig. 2. The $-\text{CHO}$ group at C1 of glucose could be easily oxidized by concentrated FeCl_3 solution, forming gluconic acid. The rupture of C1-C2 (α -scission) of glucose and/or gluconic acid resulted in formic acid and a successive carboxyl at C2. This process could continue until the formation of six molecules of formic acid.^{18,22} Alternatively, the rupture of C2-C3 (β -scission) of glucose and/or gluconic acid yielded oxalic acid, which could be further degraded to formic acid and CO_2 .²³ These mechanism explained why extended reaction hurt gluconic acid yield, as discussed above. It was expected that glucose could be dehydrated to hydroxymethylfurfural (HMF), which could be further degraded to levulinic acid and formic acid, because of the strong acidity of FeCl_3 .¹³ However, only trace of HMF and levulinic acid were detected in our study, indicating that acid-induced dehydration of glucose was minor in the concentrated FeCl_3 solution. Therefore, the formic acid detected was supposed to be from the oxidative rupture of glucose, as discussed above, not from the degradation of glucose through HMF.

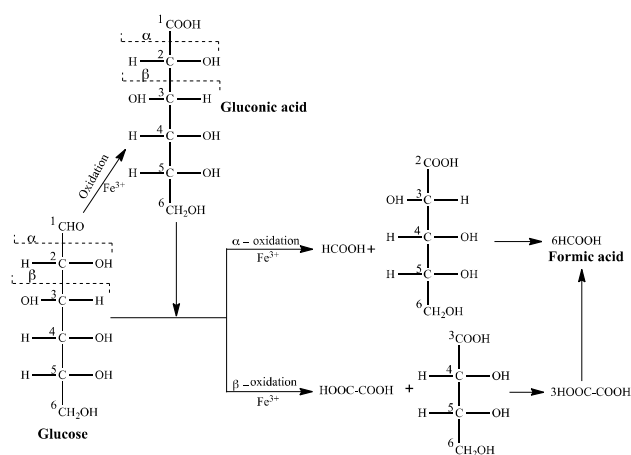

Fig. 2. Proposed pathways of glucose oxidation to gluconic acid and formic acid.

The formation of acetic acid was more complicated. To understand the pathway from glucose to acetic acid, gluconic acid was treated with FeCl_3 under the same conditions for glucose oxidation above, but no acetic acid was detected, suggesting that acetic acid was formed not via gluconic acid. Jin et al.¹⁷ proposed that glucose could be oxidized into acetic acid through two pathways. One is that glucose is first isomerized to fructose; fructose then undergoes the retro-aldol fragmentation to produce dihydroxyacetone and glyceraldehyde; these two triose fragments are transformed into lactic acid via dehydration and 1,2-hydrate shift reactions,^{6,24} and lactic acid is finally oxidized to acetic acid.¹⁷ When glucose and fructose (Table S1 in Electronic Supplementary Information) were treated with FeCl_3 , both produced acetic acid, suggesting that the isomerization of glucose to fructose might be the first step of the glucose to acetic acid. Small amount of lactic acid was detected as well. However, when lactic acid was treated with FeCl_3 under the same conditions, lactic acid was stable, and no acetic acid was detected either (Table S1), suggesting that acetic

acid was not formed via the lactic acid pathway. Another pathway proposed by Jin et al.¹⁷ is that glucose is dehydrated to HMF first, and HMF is then oxidized into acetic acid. When HMF was treated with FeCl_3 , acetic acid was detected (Table S1), verifying that this is probably a pathway of glucose oxidation to acetic acid by FeCl_3 (Fig. 3). However, acetic acid was found not the major product of HMF oxidation by FeCl_3 , suggesting the existence of other pathways. Brands and van Boekel²⁵ proposed a route that glucose is first isomerized into ketose, and the ketose is degraded into acetic acid and other products through dicarbonyl cleavage. Davidek et al.^{26,27} further verified that hydrolytic β -dicarbonyl cleavage of 1-deoxy-2,4-hexodiuloses is the major pathway leading to acetic acid from glucose, and oxidative α -dicarbonyl cleavage of 1-deoxy-2,3-hexodiuloses is a minor pathway producing acetic acid, as summarized in Fig. 3.

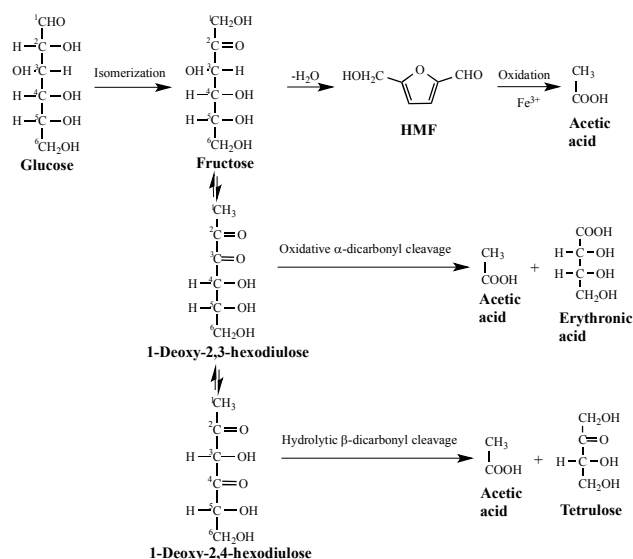

Fig. 3. Proposed pathways leading to acetic acid from glucose.

In terms of the observations in Fig. 1 that acetic acid concentration decreased with reaction time, it was initially attributed to the oxidative degradation of acetic acid.^{19,20} However, when acetic acid was treated with FeCl_3 under air or N_2 atmosphere, only small amount (<5%) was degraded to CO_2 and CH_4 (Table S1), which was not consistent with the observations in Fig. 1. Therefore, additional tests were conducted to understand the behaviors of acetic acid in FeCl_2 and FeCl_3 solutions. It was expected that adding acetic acid into FeCl_3 solution would form insoluble ferric acetate complex ($[\text{Fe}_3\text{O}(\text{OAc})_6(\text{H}_2\text{O})_3]\text{OAc}$). However, no precipitate was observed when comparable amount of acetic acid with that formed during the glucose oxidation into 40% FeCl_3 solution. This was probably because the presence of Cl^- and the deficiency of water in the concentrated FeCl_3 solution were not favorable to the formation of the ferric acetate complex. However, when adding acetic acid into 40% FeCl_2 solution, white $\text{Fe}(\text{OAc})_2$ precipitate was formed. It is known that $\text{Fe}(\text{OAc})_2$ is a white solid and soluble in water. Why $\text{Fe}(\text{OAc})_2$ was insoluble in 40% FeCl_2 solution probably because of the water-deficient condition of the concentrated FeCl_2

solution, which was confirmed by the following test. When the mixture was diluted with water, the white precipitate disappeared. The results and discussion above explained the observations in Fig. 1 why determined acetic acid decreased with reaction time. With the reaction, acetic acid was produced from the glucose oxidation, and meanwhile Fe^{3+} was reduced to Fe^{2+} . The Fe^{2+} coordinated with acetic acid, forming the $\text{Fe}(\text{OAc})_2$ precipitate, which reduced the acetic acid concentration in the supernatant.

In summary, an efficient and environment-friendly method was demonstrated in this study to oxidize glucose to gluconic acid in concentrated FeCl_3 solution. Over 50% gluconic acid yield could be achieved in 40% FeCl_3 at 110 °C within 2 hour. The major coproducts of glucose oxidation in FeCl_3 were formic acid and acetic acid with a yield of 10-20%.

Acknowledgements

Authors thank China Scholarship Council (CSC) for supporting Dr. Hongdan Zhang to conduct this research at University of Wisconsin-Madison. This work was partially supported by the grants from NSF (CBET 1159561) and USDA McIntire Stennis (WIS01597) to Dr. Xuejun Pan and by the fundamental research funds for the central Chinese universities (No.2014ZP0014).

Notes and references

Detailed experimental is described in Supporting Information. In brief, glucose (0.25 g) was dissolved in 5 mL FeCl_3 solution. The mixture was heated up to the target temperature and kept at the temperature for pre-set reaction time with stirring. All the reactions were conducted under air atmosphere. At the end of the reaction, the reaction mixture was separated by filtration; glucose and oxidation products (gluconic, formic, and acetic acids) in the filtrate were quantitated using High Performance Ion Chromatography (HPIC) and High Performance Liquid Chromatography (HPLC), respectively. The filter residues (humins) were recovered, washed thoroughly with deionized water, and oven dried at 105 °C until a constant weight. The glucose conversion and product yield were calculated using the following equations:

$$\text{Conversion (\%)} = \frac{\text{Moles of carbon in feedstock consumed}}{\text{Moles of carbon in feedstock input}} \times 100\%$$

$$\text{Product yield (\%)} = \frac{\text{Moles of carbon in organic acid}}{\text{Moles of carbon in feedstock input}} \times 100\%$$

- 1 G. W. Huber, S. Iborra, A. Corma, *Chem. Rev.*, 2006, **106**, 4044-4098.
- 2 M. Niu, Y. Hou, S. Ren, W. Wang, Q. Zheng, W. Wu, *Green Chem.*, 2015, **17**, 335.
- 3 H. Yan, Y. Yang, D. Tong, X. Xiang, and C. Hu, *Catal. Commun.*, 2009, **10**, 1558.
- 4 Y. Yan, G. Jiang, *J. Biobased Mater. Bio.*, 2014, **8**, 553.
- 5 S. Ramachandran, P. Fontanille, A. Pandey, and C. Larroche, *Food Technol. Biotech.*, 2006, **44**, 185.
- 6 W. Deng, Q. Zhang, and Y. Wang, *Catal. Today*, 2014, **234**, 31.
- 7 O. V. Singh, and R. Kumar, *Appl. Microbiol. Biot.*, 2007, **75**, 713.
- 8 X. Tan, W. Deng, M. Liu, Q. Zhang, and Y. Wang, *Chem. Commun.*, 2009, **46**, 7179.
- 9 N. Thielecke, M. Ayternir, and U. Prusse, *Catal. Today*, 2007, **121**, 115.

- 10 A. Onda, T. Ochi, K. Yanagisawa, *Cataly. Commun.*, 2011, **12**, 421.
- 11 T. Moreno, G. Kouzaki, M. Sasaki, M. Goto, and M. J. Cocero, *Carbohydr. Res.*, 2012, **349**, 33-38.
- 12 D. Rinsant, G. Chatel, and F. Jérôme. *ChemCatChem*, 2014, **6**, 3355.
- 13 L. Peng, L. Lin, J. Zhang, J. Zhuang, B. Zhang, and Y. Gong, *Molecules*, 2010, **15**, 5258.
- 14 M. Besson, P. Gallezot, and C. Pinel, *Chem. Rev.*, 2013, **114**, 1827.
- 15 L. Liu, J. Sun, C. Cai, S. Wang, H. Pei, and J. Zhang, *Bioresource Technol.*, 2009, **100**, 5865.
- 16 L. Zhang, H. Yu, P. Wang, and Y. Li, *Bioresource Technol.*, 2014, **151**, 355.
- 17 F. Jin, Z. Zhou, T. Moriya, H. Kishida, H. Higashijima, H. Enomoto, *Environ. Sci. Technol.*, 2005, **39**, 1893.
- 18 F. Jin, J. Yun, G. Li, A. Kishita, K. Tohji, and H. Enomoto, *Green Chem.*, 2008, **10**, 612.
- 19 J. Xu, Y. Zhao, H. Xu, H. Zhang, B. Yu, L. Hao, and Z. Liu, *Appl. Catal. B-Environ.*, 2014, **154**, 267.
- 20 J. Zhang, X. Liu, M. N. Hedhili, Y. Zhu, and Y. Han, *ChemCatChem*, 2011, **3**, 1294.
- 21 W. Partenheimer, *Appl. Catal. A-General*, 2011, **409-410**, 48.
- 22 W. Wang, M. Niu, Y. Hou, W. Wu, Z. Liu, Q. Liu, and K. N. Marsh, *Green Chem.*, 2014, **16**, 2614.
- 23 N. Zargari, Y. Kim, and K. W. Jung, *Green Chem.*, 2015, **17**, 2736.
- 24 M. Dusselier, P. van Wouwe, A. Dewaele, E. Makshina, and B. F. Sels, *Energy Environ. Sci.*, 2013, **6**, 1415.
- 25 C. M. J. Brads and M. A. J. S. van Boekel, *J. Agric. Food Chem.*, 2001, **49**, 4667.
- 26 T. Davidek, F. Robert, S. Devaud, F. A. Vera, and I. Blank, *J. Agric. Food Chem.*, 2006, **54**, 6677.
- 27 T. Davidek, S. Devaud, F. Robert, and I. Blank, *J. Agric. Food Chem.*, 2006, **54**, 6667.

Graphic Abstract:

A simple method to oxidize glucose into gluconic acid in concentrated FeCl_3 solution under mild conditions was developed.

