



Showcasing research from Professor Basu Saha's laboratory, School of Engineering, Lancaster University, Lancaster, LA1 4YW, UK.

From bamboo to biochar: a critical review of bamboo pyrolysis conditions and products with a focus on relevance to the developing world

This innovative study explores the production of biochar through the pyrolysis of bamboo, offering a critical analysis of pyrolysis techniques with a focus on the separation of resulting syngas into condensable (bio-oil) and non-condensable gases. The research examines how varying pyrolysis conditions influence product yield and composition, with the dual aim of maximising biochar output and minimising greenhouse gas emissions. By addressing the environmental and technological aspects of biomass conversion, this work aligns with the UN Sustainable Development Goals 12, 13, and 15, with particular relevance to the developing world.

Image reproduced by permission of Basudeb Saha from *RSC Sustainability*, 2025, **3**, 2712.

As featured in:



See Basudeb Saha *et al.*, *RSC Sustainability*, 2025, **3**, 2712.

Cite this: *RSC Sustainability*, 2025, 3, 2712

From bamboo to biochar: a critical review of bamboo pyrolysis conditions and products with a focus on relevance to the developing world

Elish Chambers,^a Matthew Hassall,^b Dominic Johnson,^c Conall Mcgoran,^d Olivia Williams,^e Aden Blair,^f Freddie Catlow^g and Basudeb Saha *^h

This innovative study explores the production of biochar from the pyrolysis of bamboo, critically analysing various pyrolysis methods with a particular focus on potential separation methods for the resulting syngas mixture, which includes condensable (bio-oil) and non-condensable gases. The effects of pyrolysis conditions on product yield and composition are examined, aiming to maximise biochar yield while minimising greenhouse gas emissions. The study applies the concept of slow pyrolysis to a real-world scenario at Elpitiya Plantation in Sri Lanka, evaluating different process options. The potential benefits of biochar application for improving local soil health and mitigating greenhouse gas emissions are also discussed. For the designed system, an operating temperature range of 250–300 °C was selected to achieve a biochar production rate of 1000 kg per day, processing 2080 kg per day of bamboo feedstock. The resulting syngas mixture is directed through a condenser operating at 90 °C, yielding 538 kg per day of bio-oil and 918 kg per day of combustible gases, which are flared to generate 18.41 kW per day of energy.

Received 14th December 2024
Accepted 9th May 2025

DOI: 10.1039/d4su00800f

rsc.li/rscsus

Sustainability spotlight

This article examines the production of high-yield biochar from the pyrolysis of bamboo, offering a critical review of the various methods used, with a particular emphasis on potential separation techniques for the resulting syngas mixture. We believe this article provides a novel perspective and a comprehensive evaluation of bamboo biomass pyrolysis for achieving high biochar yields. It explores potential applications in the developing world while highlighting the benefits of biochar for improving local soil health and reducing greenhouse gas emissions. This aligns with the UN's Sustainable Development Goals 12, 13, and 15, promoting sustainable practices with a focus on relevance to the developing world.

1. Introduction

The production of biochar is increasingly recognised as an effective approach for stabilising carbon, contributing to the reduction of greenhouse gas emissions. This reduction plays a vital role in mitigating global warming, thereby promoting environmental sustainability for future generations. Global

warming is a critical environmental concern and has led to various socioeconomic problems, such as rising sea levels, climate change, species extinction, and food insecurity.¹ The European Commission reported 2011–2020 as the warmest decade on record, largely accelerated by intensive greenhouse gas (GHG) emissions into the atmosphere, according to the International Panel on Climate Change (IPCC).^{1–3} With the world population set to reach 9 billion by 2050, the problem is expected to increase without intervention.⁴ Scientific efforts have been made to advance renewable energy production methods to reduce GHG emissions, as well as in carbon capture technologies to actively remove GHGs from the atmosphere.^{4,5} Developed countries, such as Norway and the United Kingdom, are demonstrating success in the deployment of advanced carbon capture technologies due to appropriate national policies, resources, and funding.⁵ Developing countries, with reduced resource abundance, may benefit from alternative, affordable technologies.⁵

Biomass refers to organic materials produced from plants, animals and microorganisms that are abundant, renewable, and inexpensive.¹⁶ It is considered the largest available

^aSchool of Engineering, Lancaster University, Lancaster, LA1 4YW, UK. E-mail: elish2chambers@hotmail.co.uk

^bSchool of Engineering, Lancaster University, Lancaster, LA1 4YW, UK. E-mail: hassallmt@gmail.com

^cSchool of Engineering, Lancaster University, Lancaster, LA1 4YW, UK. E-mail: domjohnson195@gmail.com

^dSchool of Engineering, Lancaster University, Lancaster, LA1 4YW, UK. E-mail: mcgoranconall@gmail.com

^eSchool of Engineering, Lancaster University, Lancaster, LA1 4YW, UK. E-mail: o.f.williams@lancaster.ac.uk

^fSchool of Engineering, Lancaster University, Lancaster, LA1 4YW, UK. E-mail: a.blair1@lancaster.ac.uk

^gPlanboo, Nobelbergsgatan 6, Nacka, 131 54, Sweden. E-mail: freddie@planboo.eco

^hSchool of Engineering, Lancaster University, Lancaster, LA1 4YW, UK. E-mail: b.saha@lancaster.ac.uk



renewable carbon source and currently supplies around 14% of the global yearly energy consumption.⁷ The conventional, first-generation biomass includes food resources, which draw usage constraints due to concerns surrounding food insecurity.¹⁷ Non-edible biomass, second generation onwards, includes lignocellulose (second generation), algae (third generation), and organic wastes (fourth generation) and has been widely reported in the literature due to favourable usage over edible resources.¹⁷

The valorisation of biomass can be achieved *via* thermochemical or biochemical routes to produce biofuels or other value-added chemicals, as in Fig. 1. Thermochemical production routes include combustion, pyrolysis, and gasification, where combustion typically produces useful heat only whilst pyrolysis and gasification processes promote the production of a wide range of products including gaseous, condensable vapours and solids.^{1,6,7}

Green process engineering constitutes a pivotal strategy with the potential to transform inefficient processes into sustainable practices, thereby delivering significant benefits to the economy, the environment, and society.⁸ Pyrolysis is the thermal decomposition of biomass in the absence of oxygen and has gained popularity in literature due to its ability to produce a liquid bio-oil.⁹ It can be classified into slow, fast, and flash pyrolysis in terms of heating rate. Slow pyrolysis favours a high biochar yield, whilst flash conditions deliver a higher gaseous yield.^{9,10} Recent publications have reported on the production of liquid biofuels and carbon adsorbents through

the pyrolysis of non-edible feedstocks,¹¹ and also explored the potential of co-processing two underutilised waste streams to yield valuable pyrolysis products.¹²

Increasingly, the solid biochar pyrolysis product is attracting attention to literature due to its potential role in carbon sequestration as well as applications as an enhancing soil-enhancing agent.^{6,13,14} Bamboo is an excellent candidate for carbon sequestration due to its growth rate, which enables the sequestration of approximately four times more carbon dioxide than average timber biomass.¹⁵ Planboo is a company recognising the potential of biochar and biochar production in the developing world by utilising fast-growing, invasive bamboo on tea plantations to produce biochar through slow pyrolysis.¹⁶

This article presents a comprehensive and critical review of pyrolysis with a distinct focus on using bamboo biomass due to its fast-growing rate and abundance surrounding the Elpitya plantations. The specificity towards developing world applications presents a unique advantage of making the production of stable carbon more accessible. It explores potential applications in the developing world while highlighting the benefits of biochar for improving local soil health and reducing greenhouse gas emissions. There is a further focus on the identification of suitable conditions to promote biochar yield as well as the assessment of available technologies to utilise the range of products produced. Several techniques for the separation of liquid and gaseous products are reviewed, with a look to onward product use and upgrading requirements to maximise the use

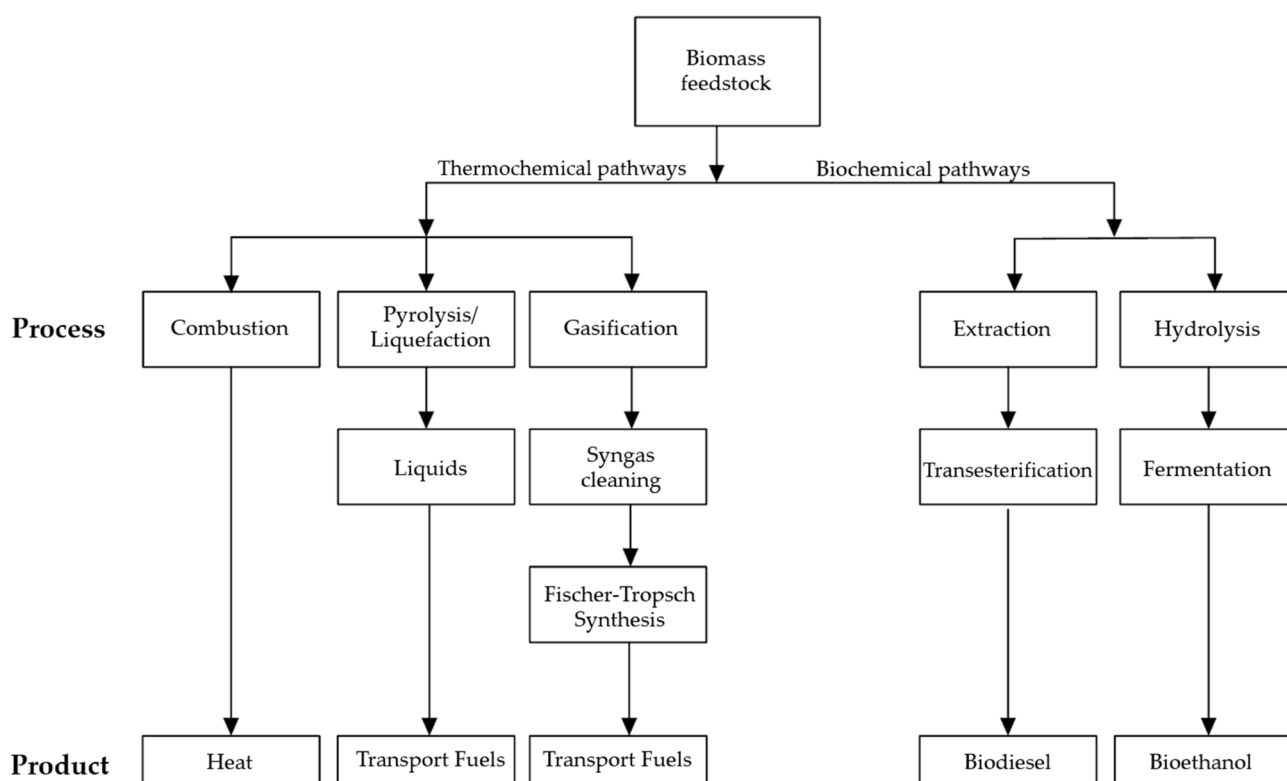

Fig. 1 A schematic of the possible biomass valorisation pathways and their major product (adapted from ref. 7). Reproduced from ref. 7 with permission from [MDPI Publisher], copyright [2020].



of these products if deemed possible. Finally, the article features a case study of the operation of bamboo pyrolysis in the developing world to support affordable carbon sequestration methods. This study aligns with the UN's Sustainable Development Goals (UNSDGs) 7 (Affordable and clean energy), 12 (Responsible consumption and production) and 13 (Climate action), promoting sustainable practices with a focus on relevance to the developing world.

2. Pyrolysis

Pyrolysis is the thermochemical decomposition of organic material at elevated temperatures in the absence of oxygen. The word originates from Greek vocabulary, with 'pyro' meaning fire and 'lysis' meaning separation into constituent parts.¹⁰ Pyrolysis is distinct from normal complete combustion, which occurs in the presence of oxygen to produce carbon dioxide and water.^{9,17}

The pyrolysis process is characterised by the decomposition of polymer chains in biomass macromolecules to produce condensable volatiles (bio-oil), non-condensable gases and solid biochar. The liquid product also includes a viscous tar containing compounds of a higher molecular weight than the bio-oil.^{9,18} The relative quantities and compositions of each product phase are heavily dependent on reaction conditions.¹⁸

Depending on the heating rate and reactor residence time, pyrolysis is classified into slow, fast, and flash pyrolysis, where slow pyrolysis favours char production whilst fast conditions support higher bio-oil yields, desirable for the industrial production of biofuels.¹⁹

Biomass slow pyrolysis has been utilised for thousands of years as a method to produce charcoal from wood as well as tar for sealing wooden boats in ancient Egypt.⁹ Current research is largely focused on fast pyrolysis due to its ability to produce a crude bio-oil which can be further upgraded to biofuel or bio-based chemicals.^{10,18}

2.1. Pyrolysis mechanism

The mechanism through which pyrolysis occurs is complex with many reaction pathways and intermediate products possible. The process can be largely considered as two distinct phases, namely primary and secondary reactions, as seen in Fig. 2.²⁰ It is noted that both the process conditions and biomass feedstock significantly influence the reaction pathway and hence the final product distribution.

In the primary stage, three main mechanisms are considered, which are charring, depolymerisation and fragmentation:^{19,21,22}

1. Charring: char is an aromatic polycyclic carbon which results from the combination or condensation of benzene rings.

2. Depolymerisation: a dominant reaction route in which polymer bonds within the biomass are cracked, producing volatile molecules.

3. Fragmentation: covalent bonds within polymers and unit monomers are ruptured to produce short-chain compounds and incondensable gases.

Unstable primary compounds may undergo further reactions, defined as secondary reactions, such as cracking or recombination. Cracking yields lower-weight molecular compounds whilst recombination results in the production of heavier compounds, which may conclude with the formation of a secondary char.¹⁹

The exact overall biomass pyrolysis mechanism is not completely clear due to the lack of understanding of the interaction between the major components of biomass, which are cellulose, hemicellulose, and lignin.^{19,22} Specific models exist in the literature for each major component of biomass, although they are not considered within the scope of this paper due to the sheer volume of independent and contradicting models available.²¹

2.2 Types of pyrolysis

The typical operating parameters and products differ for each classification and are shown in Table 1. Although no sharp



Fig. 2 Primary and secondary mechanisms of the pyrolysis process (adapted from ref. 20). Reproduced from ref. 20 with permission from [MDPI Publisher], copyright [2018].



Table 1 Typical conditions for slow, fast and flash pyrolysis¹⁰

	Residence time (s)	Heating rate (K s ⁻¹)	Particle size (mm)	Temp. (K)	Product yield (%)		
					Oil	Char	Gas
Slow	450–550	0.1–1	5–50	550–950	30	35	35
Fast	0.5–10	10–200	<1	850–1250	50	20	30
Flash	<0.5	>1000	<0.2	1050–1300	75	12	13

borders separate these defined industrial categorisations with crossover observed in the literature.^{9,10}

It is noted that operating conditions alone do not guarantee product yield; biomass type, reactor design, and onward separation techniques have a significant impact on the final product quantities.

2.2.1. Slow pyrolysis. Slow pyrolysis is conducted at relatively low temperatures (<500 °C) over long periods (up to several days) with low heating rates (0.1 to 2 °C per second). Under these conditions, char is the major product formed as long residence times of pyrolysis products allow for repolymerisation and recombination reactions to occur, resulting in longer carbon chains associated with solid forms.⁹

Reactors for slow pyrolysis processes are classified into kilns, convertors, and retorts. Kilns are a traditional technology utilised largely for char production alone whilst retorts and convertors are developed to recover biochar as well as other

products (liquid and syngas).⁶ Retort systems may be designed to support the separation of the phases to yield desired products (such as bio-oil) or may utilise the energy contained within the liquid and gaseous phases (*via* combustion) to enable the autothermal operation of the system.⁶

Commercial slow-pyrolysis plants are reported less frequently in literature, likely due to the low bio-oil yield drawing less industrial attention. Mitsubishi Heavy Industries (Japan) commercially operates a slow pyrolysis process of 100 tonnes per day of dried, ground wood chips, where syngas is the desired primary product.²³ A rotating kiln (operating at 400–500 °C) produces syngas and biochar which are separated *via* cyclone; the syngas is combusted to power a 1400 kW steam turbine for electricity generation, as well as provide heat for the kiln. Biochar is recovered for onward use as a soil additive.²³

2.2.2. Fast pyrolysis. Fast pyrolysis is characterised by higher heating rates and shorter vapour residence times than



Fig. 3 A schematic of a fast-pyrolysis fluidized bed process (adapted from ref. 21). Reproduced from ref. 21 with permission from [Elsevier Publisher], copyright [2015].



slow pyrolysis, promoting a higher bio-oil (liquid) yield. The operating temperature range is typically 550–1250 °C, where the required feedstock particle size is small to favour rapid escape of volatiles and avoid further contact with hot char particles, which may reduce liquid yield.^{21,24}

Fast pyrolysis demands high heat and mass transfer rates in the reaction zone, with rapid cooling of the vapour phase products to limit secondary reactions.²⁵ Several reactor configurations exist for fast pyrolysis, including ablative systems, fluidized beds, rotating cones, moving beds and vacuum systems.^{21,26}

A schematic of a fluidized bed system to produce liquid products is shown in Fig. 3.²¹ Several additional technologies are required to support the production of the pyrolysis liquid product. Solid char residue is removed from the reactor product stream *via* the application of a cyclone. A quencher unit condenses the vapour product to form the liquid product; non-condensable gases may be combusted for heat generation to improve process efficiency.

Additional complexity may be introduced into the system by the introduction of grinding and drying units pre-reactor to ensure uniform particle properties. Despite this, fast pyrolysis technology is used globally to produce liquid bio-oil and is receiving increasing popularity in the biofuel and speciality chemical sectors.^{10,20} The liquid bio-oil has a heating value half that of gasoline and has the additional potential to supply several valuable chemical commodities such as food flavourings, resins and fertilisers.^{10,27}

Operational fast pyrolysis plants exist in Finland, the Netherlands and Canada, with further construction ongoing in Finland and Sweden.^{26,28} A summary of current operational plants and those under construction is provided in Table 2.

2.2.3. Flash pyrolysis. Flash pyrolysis is distinct from fast pyrolysis and is characterised by higher heating rates and shorter vapour residence times. Heating rates of up to 2500 °C per second may be observed, with the process reaching completion in less than 0.5 seconds. Flash pyrolysis is characterised by a typical temperature range of 400 °C to 1000 °C.⁹ A smaller feedstock particle size than fast pyrolysis is necessary to support the high heating rates.²⁹

Flash pyrolysis is considered an advanced pyrolysis technology through which a large quantity of syngas and high-quality bio-oil (with low water content) can be recovered.²⁹ Despite potential advantages, the process has major technical drawbacks, including thermal instability, the corrosive nature of oil, solid particles in oil and a viscosity which may increase with time due to the catalyst in biochar.^{10,30}

Reactor configurations for flash pyrolysis are similar to fast pyrolysis, with fluidized beds and rotating cone designs reported in the literature.^{19,20,24}

2.3. Pyrolysis products

The products associated with bamboo and other woody biomass pyrolysis processes can be broadly split into three categories: biochar, bio-oil, and non-condensable gases. Biochar refers to a solid charcoal-like material with a significant carbon content, also composed of hydrogen, oxygen, and nitrogen, with small amounts of potassium and phosphorus.³¹ On the other hand, bio-oil is a series of largely organic compounds such as carboxylic acids, alcohols, and aldehydes, which can be used to produce products such as biofuels.³² The non-condensable gas fraction consists largely of carbon dioxide, carbon monoxide, methane, and hydrogen, although relatively small amounts of other light hydrocarbons may also be present. The proportions of each fraction produced through pyrolysis and their respective compositions vary as the process and operating conditions are altered.³³

There are many factors which affect the yield of each pyrolysis product, as well as their relative compositions; slow pyrolysis often generates significant quantities of biochar and non-condensable gases, whilst fast pyrolysis often generates more bio-oil.³⁴ Factors such as temperature, residence time, pressure, feed conditions, and production rate all influence the nature of the pyrolysis products.³⁵ It is also worth noting that although pyrolysis can be performed in a variety of reactor configurations, many of these, such as fluidized bed and pressurised systems, are complex in nature and of limited feasibility in the developing world. For developing world applications, simple fixed bed configurations would likely prove most feasible.³⁴

2.3.1. Temperature. In general, as the operating temperature of the pyrolysis process increases, the biochar yield rapidly decreases because of thermal decomposition. The decomposition of the biochar fraction simultaneously results in an increased yield of bio-oil and non-condensable gases. However, at sufficiently high temperatures (over 500 °C), the biochar yield remains relatively constant, as the bio-oil fraction preferentially undergoes degradation, leading to increased production of non-condensable gases.³³ Table 3 demonstrates the impact of temperature on the relative yield of each fraction in the pyrolysis of bamboo feedstock.

Beyond yield, temperature also impacts the chemical composition of each fraction, which can significantly affect the associated properties of the product. Increased temperatures

Table 2 Operational fast pyrolysis plants and their fast pyrolysis bio-oil (FPBO) yield^{26,28}

Organisation	Country	Technology	FPBO (MW _{th})	Phase	Operational
Savon Voima	Finland	VTT fluidized bed riser	30	Operational	2013
BTG-BTL/EMPYRO (Twence)	Netherlands	Rotating cone	15	Operational	2015
Ensyn	Canada	Ensyn fluidized bed riser	8	Operational	2006
Ensyn/Envergent	Canada	Ensyn fluidized bed riser	30	Commissioning	—
Green Fuel Nordic	Finland	Rotating cone		Construction	—
Pyrocell	Sweden	Rotating cone		Construction	—



Table 3 Effect of temperature on overall product yield in bamboo pyrolysis³⁵

Temperature (°C)	Biochar yield (wt%)	Bio-oil yield (wt%)	Gas yield (wt%)
300	49.30	26.50	23.20
400	30.70	35.20	34.10
500	26.00	36.60	37.40
600	24.30	36.10	39.60
700	23.60	34.10	42.30

Table 4 Effect of temperature on biochar chemical composition³⁵

Temperature ^a (°C)	C (wt%)	H (wt%)	N (wt%)	S (wt%)	O (wt%)
300	68.60	3.90	0.90	0.10	26.50
400	74.60	3.50	0.90	0.10	20.80
500	79.10	2.50	1.00	0.10	17.20
600	84.00	1.70	1.00	0.10	13.20
700	88.30	1.30	1.10	0.10	9.20

^a Notably, as pyrolysis temperature increases, small amounts of phosphorus and potassium are evidenced with the biochar composition, becoming more prominent at raised temperature.³¹

promote processes such as aromatisation, which increases the stability of biochar, thus making it more suitable for carbon sequestration, although at the compromise of overall yield.³⁶ The impact of temperature on each product fraction is explored in turn.

2.3.1.1 Biochar. Increased temperatures greatly alter the chemical composition of biochar, where elevated temperatures induce significant increases in carbon content whilst significantly reducing the presence of oxygen and hydrogen. Nitrogen content increases marginally with temperature, whilst literature reporting of sulphur content differs, with some authors reporting a largely invariant content with temperature,³³ whilst

others suggest a strong correlation with temperature.³⁷ Table 4 details the variation in the chemical composition of biochar obtained through the pyrolysis of bamboo at different temperatures.³³

Structurally, increased temperatures result in a significant increase in the biochar surface area, as well as a modest increase in energy content.³³ Greater temperatures also enhance the stability of the carbon compounds within the biochar, due to the promotion of highly stable amorphous aromatic ring structure formation. High stability improves biochar resistance to physical and microbial breakdown, ensuring more effective carbon sequestration.³⁸ This is reflected by a decreased presence of volatile matter in biochar produced at high temperatures and a greater proportion of fixed carbon. However, the structural benefits and stability favoured by high temperatures are at the compromise of the overall biochar yield, which is decreased significantly whilst ash production increases.³⁷ This is reflected in the analysis of biochar produced in bamboo pyrolysis provided in Table 5.

2.3.1.2. Bio-oil. As pyrolysis temperatures increase, the carbon and water content of the produced bio-oil increases, whilst the hydrogen content is slightly reduced. The yield of nitrogen and sulphur appears to be independent of temperature; however, no clear correlation is derived for oxygen content.³³ In general, bio-oil produced at relatively low temperatures contains large quantities of highly oxygenated polar components, the presence of which decreases as the temperature is raised.³⁹ The effect of temperature on the bio-oil obtained from bamboo pyrolysis is summarised in Table 6.

2.3.1.3. Non-condensable gases. The composition of the non-condensable gas fraction is greatly influenced by temperature. At low temperatures, carbon dioxide and carbon monoxide dominate the gas composition. With the increasing temperature, the carbon dioxide yield drops significantly, whilst the yields of carbon monoxide, hydrogen, and methane increase. Continued temperature increase delivers a reduction in the yield of carbon

Table 5 Effect of temperature on biochar properties³⁵

Temperature (°C)	Volatile (wt%)	Fixed C (wt%)	Ash (wt%)	HHV (MJ kg ⁻¹)	SSA (m ² g ⁻¹)
300	30.90	65.20	3.90	25.40	12.30
400	25.10	71.50	3.30	27.50	26.10
500	20.50	75.40	4.10	28.20	48.40
600	12.90	82.80	4.30	29.00	60.90
700	9.40	86.40	4.30	29.60	64.50

Table 6 Effect of temperature on bio-oil chemical composition³³

Temperature (°C)	C (wt%)	H (wt%)	N (wt%)	S (wt%)	O (wt%)	Moisture (wt%)
300	25.50	10.20	1.90	0.10	62.40	65.20
400	29.60	9.40	2.10	0.10	58.90	67.90
500	29.70	8.90	1.90	0.10	59.30	68.30
600	29.40	8.40	2.00	0.10	60.20	68.60
700	28.50	8.40	2.00	0.10	61.00	68.90



Table 7 Effect of temperature on the non-condensable gases³³

Temperature (°C)	CO ₂ (v%)	CO (v%)	CH ₄ (v%)	H ₂ (v%)	C ₂₊ (v%)	HHV (MJ kg ⁻¹)
300	66.70	27.30	1.60	2.90	1.50	3.60
400	47.90	36.30	6.40	8.10	1.30	6.70
500	41.30	36.40	11.80	9.20	1.30	9.10
600	37.90	33.50	12.30	14.20	2.10	10.70
700	33.40	31.80	13.70	19.80	1.30	11.90

monoxide, whilst the presence of hydrogen and methane continues to climb.³³ The increased production of hydrogen and methane associated with elevated temperatures is associated with increased breakdown of heavy and complex compounds into lighter substances.⁴⁰ In contrast, the yield of small hydrocarbons (C₂₊) is largely unaffected by temperature variation, as these molecules already exist in their smallest state.

The increased generation of combustibles such as hydrogen and methane results in a much greater energy content in the non-condensable gas produced at high temperatures.³³ The effect of temperature on the non-condensable gas fraction formed from bamboo pyrolysis is outlined in Table 7.

2.3.2. Residence time. Increased residence time promotes the breakdown of large organic structures to smaller compounds, such as hydrogen, as well as impacts the macro-structure of pyrolysis products, such as biochar.⁴¹ Residence time, therefore, affects both the yield and composition of the pyrolysis products, with Table 8 demonstrating the effect of residence time on the overall product yield from rice straw pyrolysis.

2.3.2.1. Biochar. The fixed carbon content of biochar formed from woody biomass increases with prolonged residence time, whilst the volatile matter within the biochar decreases.⁴³ Overall, increased residence time lowers the yield of biochar whilst increasing the ash yield, although data concerning ash production vary significantly between studies. Residence time has no clear effect on the overall chemical composition of biochar, with varying findings reported in the literature. However, the biochar energy content was shown to

increase consistently with residence time.⁴² Tables 9 and 10 summarise the impact of residence time on biochar produced from the pyrolysis of rice straw and woody biomass, respectively.

Interestingly, increasing residence time appears to increase biochar-specific surface area, most likely due to the release of volatile components forming pores. However, at excessive residence times, the phenomenon is reversed with an apparent decrease in the biochar-specific surface area. This effect is possibly attributed to the thermal degradation of carbon structures, resulting in the collapse of pores.³⁷

2.3.2.2. Bio-oil. Bio-oil yields generally increase with extended residence times, where the chemical composition of the bio-oil also changes. In general, the bio-oil increases in carbon and nitrogen content, although no clear trend for hydrogen and oxygen content is derived. The increased carbon content increases the energy content of bio-oil.⁴² The effect of residence time on bio-oil is highlighted by data collected through rice straw pyrolysis, as shown in Table 8 and the effect of residence time on bio-oil chemical composition is presented in Table 11.

Table 8 Effect of residence time on product yield⁴²

Residence time (h)	Biomass (kg)	Biochar (kg)	Bio-oil (kg)	Gas (kg)
1	25	14.30	7.50	3.00
2	25	12.50	8.00	4.30
3	25	11.70	8.50	4.80

Table 10 Effect of residence time on biochar chemical composition⁴³

Temperature (°C)	Residence time (h)	Volatile (wt%)	Fixed C (wt%)	Ash (wt%)
300	0.5	73.40	25.40	1.10
300	1	64.00	34.30	1.70
300	2	54.80	43.40	1.80
300	4	47.80	50.50	1.70
300	8	38.70	59.50	1.80
300	24	36.30	62.10	1.70
600	0.5	15.90	80.30	3.80
600	1	14.40	82.30	3.60
600	2	11.10	87.50	3.20
600	4	9.00	88.70	3.00
600	8	7.30	90.30	2.40
600	24	6.20	91.40	2.40

Table 9 Effect of residence time on biochar chemical composition⁴²

Residence time (h)	C (wt%)	H (wt%)	N (wt%)	O (wt%)	HHV (MJ kg ⁻¹)
1	65.90	5.10	3.80	25.20	17.60
2	66.30	5.00	3.60	24.60	18.00
3	66.90	4.90	3.40	23.80	18.50



Table 11 Effect of residence time on bio-oil chemical composition⁴²

Residence time (h)	C (wt%)	H (wt%)	N (wt%)	O (wt%)	HHV (MJ kg ⁻¹)
1	31.80	7.30	2.00	59.00	13.30
2	32.00	7.42	2.10	58.40	13.90
3	32.30	6.67	2.20	58.90	14.00



Fig. 4 Gas stream composition time evolution at 400°. The data presented in the figure were obtained from the ref. 44.

2.3.2.3. Non-condensable gases. The yield of the non-condensable gas pyrolysis fraction follows a characteristic pattern concerning residence time. Initial production is low; however, as pyrolysis residence time progresses, the production of the gaseous phase increases sharply to reach a maximum. Beyond this maximum yield, the yield falls with an increasing residence time.⁴⁴

With respect to composition, as residence time increases, the thermal cracking of heavy hydrocarbons and the relatively slow breakdown of lignin result in significant changes to the gas

composition. At low residence times, carbon dioxide and carbon monoxide dominate the gas stream composition profile. However, as the residence time increases, heavy compounds undergo slow thermal degradation mechanisms, yielding increasing quantities of methane and hydrogen. This increase in combustible gases increases the specific energy content of the gas fraction.⁴²

When an increase in residence time is combined with an increase in temperature, the effect on the gas fraction composition is much more pronounced. The gas composition profile



Fig. 5 Gas stream composition time evolution at 600°. The data presented in the figure were obtained from the ref. 44.





Fig. 6 Gas stream composition time evolution at 800°. The data presented in the figure were obtained from the ref. 44.

undergoes a discrete transition with increasing time at low temperatures, whilst a more drastic transformation is observed at high temperatures, with methane and hydrogen generation increasing significantly.⁴⁴ This is illustrated by Fig. 4, 5 and 6, which demonstrate the effect of residence time on the gas stream composition for the pyrolysis of woody biomass at 400 °C, 600 °C and 800 °C, respectively.

2.3.3. Heating rate. Increased heating rates induce decreased biochar yields and increased formation of non-condensable gases.⁴⁵ The production of bio-oil can be increased with the heating rate; however, the yield may decrease without a high degree of process control.⁴⁶

2.3.3.1. Biochar. As the heating rate increases, the carbon and hydrogen content of the biochar appear to decrease, whilst the oxygen and nitrogen content increase; sulphur content remains unaffected by the heating rate.⁴⁵ This trend can be observed in Table 12, demonstrating biochar composition produced through the pyrolysis of bamboo at varying heating rates.

Table 12 Effect of heating rate on the chemical composition of biochar⁴⁵

HR (°C min ⁻¹)	C (wt%)	H (wt%)	N (wt%)	S (wt%)	O (wt%)
5	88.10	1.20	1.00	0.10	9.50
10	89.70	1.20	1.10	0.10	7.90
20	87.20	1.10	1.20	0.10	10.30
30	85.90	0.90	1.20	0.10	11.90

Table 13 Effect of heating rate on the properties of biochar⁴⁵

HR (°C min ⁻¹)	Volatile (wt%)	Fixed C (wt%)	Ash (wt%)	HHV (MJ kg ⁻¹)	SSA (m ² g ⁻¹)
5	6.60	88.50	4.90	28.00	64.30
10	5.30	89.80	4.90	28.30	64.80
20	4.50	89.00	6.50	27.80	69.60
30	3.30	87.60	9.20	27.30	72.60

The volatile, fixed carbon and energy content of biochar tends to decrease with an increased heating rate, as opposed to the ash content, which increases significantly. Furthermore, increased heating rates enhance the specific surface area of the biochar.⁴⁵ This can be seen from the data in Table 13, collected from biochar obtained *via* bamboo pyrolysis.

2.3.3.2. Bio-oil. The yield of bio-oil typically increases as the heating rate is raised,⁴⁶ with an associated decrease in carbon content and a marked increase in oxygen content. In contrast, the heating rate has no observable trend on the quantities of hydrogen, nitrogen, or sulphur present, as shown in the analysis of bio-oil produced by bamboo pyrolysis in Table 14.⁴⁵

The pH and viscosity of bio-oil appear to increase slightly with the heating rate. Meanwhile, the water content of bio-oil obtained *via* fast pyrolysis heating rates is typically lower than that yielded through slow pyrolysis heating rates. Moreover, the presence of small molecule substances is greater in bio-oil generated by slow pyrolysis, most likely due to the slow nature of thermochemical breakdown mechanisms.⁴⁵ Table 15 describes the above trends acquired through the examination of bio-oil produced during bamboo pyrolysis.

2.3.3.3. Non-condensable gases. Heating rates appear to have very little effect on the composition of the non-condensable gas fraction. An increased heating rate appears to cause a slight decrease in carbon dioxide and a minor increase in methane yield, with no obvious effect on carbon monoxide or hydrogen production.⁴⁵ Table 16 summaries the impact of heating rate on the non-condensable gas fraction produced in bamboo pyrolysis.



Table 14 Effect of heating rate on the chemical composition of bio-oil⁴⁵

HR (°C min ⁻¹)	C (wt%)	H (wt%)	N (wt%)	S (wt%)	O (wt%)
5	69.30	6.10	1.60	0.30	22.70
10	67.50	6.10	1.90	0.20	24.30
20	70.40	5.80	2.00	0.30	21.50
30	65.50	6.30	1.80	0.30	26.10

Table 15 Effect of heating rate on the properties of bio-oil⁴⁵

HR (°C min ⁻¹)	Moisture (%)	pH	Viscosity at 40 °C (mm ² s ⁻¹)
5	68.50	2.50	1.168
10	69.50	2.60	1.026
20	65.40	2.80	1.172
30	62.80	2.80	1.210

Table 16 Effect of heating rate on the composition of the non-condensable gas fraction⁴⁵

HR (°C min ⁻¹)	CO ₂ (v%)	CO (v%)	CH ₄ (v%)	H ₂ (v%)
5	35.70	20.10	11.90	25.10
10	33.90	22.00	10.60	27.80
20	36.10	18.20	15.10	22.60
30	33.70	22.40	12.80	24.90

Table 17 Effect of feed particle size on biochar and ash production³⁷

Particle size (μm)	Biochar yield (wt%)	Ash (wt%)
1000–2000	21.60	7.90
355–500	22.90	9.60

Table 18 Effect of feed particle size on biochar composition³⁷

Particle size (μm)	C (wt%)	H (wt%)	N (wt%)	S (wt%)	O (wt%)
1000–2000	74.60	0.10	0.40	0.20	16.80
355–500	74.80	1.20	0.40	0.80	13.30

2.3.4. Feed conditions. Pyrolysis feedstock can be pre-treated, for example, through drying or milling. Pre-treatment processes can significantly influence pyrolysis yields, fractional composition, and structural characteristics. Moisture

reduction is a commonly employed pyrolysis pre-treatment performed to reduce water content.⁴⁶

2.3.4.1. Particle size. Utilisation of a finer feed material results in an apparent increase of biochar yield, as well as slightly increasing its carbon and nitrogen content. Finer feed material is also associated with biochar with increased hydrogen and sulphur yield. On the other hand, feedstock with larger particle size is associated with a biochar product with raised oxygen content and significantly less ash.³⁷ Increased particle size often leads to greater temperature gradients through the pyrolysis material, meaning the core of the particle is of significantly lower temperatures than the external surface. This is thought to support greater biochar yields, although practical applications do not always support the theory.⁴⁷ The effect of feed particle size on the yield and properties of biochar formed from the pyrolysis of bamboo is summarised in Tables 17 and 18.

2.3.4.2. Moisture content and torrefaction. Many feed pre-treatment methods target parameters such as moisture content. Torrefaction is one such process, referring to a mild pyrolysis step carried out in an inert atmosphere. Both dry and wet torrefaction exist, dry torrefaction refers to a process in which biomass is heated in an oxygen-deficient environment, whilst wet torrefaction refers to a hydrothermal process in hot compressed water at a slightly lower temperature.

A study conducted with woody biomass demonstrates that, compared to regular untreated feed, the moisture content of feedstock pre-treated by torrefaction is significantly reduced, whilst the presence of volatile components is also slightly reduced. On the other hand, the fixed carbon content for both pre-treated feedstocks is noticeably greater than that associated with untreated feed. The dry pre-treated feed edges the wet pre-treated feed in terms of fixed carbon content. However, the dry pre-treated feed produced more ash than the untreated feed, whilst the wet pre-treated feed produced less. Both forms of pre-treatment are known to increase the energy content per unit mass of feed, though the dry treatment increased this energy content to a greater extent.⁴⁸ These details are condensed in Table 19.

The chemical analysis demonstrates that the overall carbon content of the dry-treated feed is moderately greater than the other feedstocks, whilst the oxygen and hydrogen content was somewhat reduced. In addition, wet-treated feed boasts a greater presence of hydrogen, whilst both pre-treatment methods reduce the proportion of sulphur and increase the proportion of nitrogen.⁴⁸ Therefore, such pre-treatment methods appear to increase the quality of the biochar obtained. This analysis is demonstrated in Table 20.

Table 19 Effect of pre-treatment on biomass properties⁴⁸

Feed	Water (wt%)	Volatile (wt%)	Fixed C (wt%)	Ash (wt%)	HHV (MJ kg ⁻¹)
Regular	8.70	78.30	12.60	0.40	17.40
Dry treated	3.60	73.70	21.90	0.80	20.70
Wet treated	4.60	74.20	21.00	0.20	19.10



Table 20 Effect of pre-treatment on biomass chemical composition⁴⁸

Feed	C (wt%)	H (wt%)	N (wt%)	S (wt%)	O (wt%)
Regular	44.90	5.00	0.10	0.04	40.90
Dry treated	54.70	4.60	0.20	0.03	36.20
Wet treated	48.70	5.40	0.20	0.03	40.90

It is documented that wet-treated feed is said to have greater pellet ability, grindability and hydrophobicity. Overall chemical analysis demonstrates that wet torrefaction pre-treatment increases the abundance of oxygen-containing functional groups. Meanwhile, dry torrefaction pre-treatment significantly reduces the presence of such groups and promotes aromatization.⁴⁸

3. Pyrolysis feedstock

To facilitate effective pyrolysis, an appropriate raw material must be identified. Ideally, this material should be widely available and have a high carbon content and porosity. Numerous studies suggest that bamboo forms higher-quality biochar than alternative materials; this is largely due to bamboo's superior atmospheric carbon dioxide sequestration when compared to other land-based plants, resulting in a high-carbon biochar product.⁴⁹ Bamboo is abundant in developing countries, however, it is typically unused and undesired as it is considered an invasive species due to its high growth rate.^{50,51} It, therefore, presents strong potential for application as a raw material for pyrolysis.

3.1. Beneficial properties of bamboo feedstock

Bamboo is among the fastest-growing plants on Earth, with an annual growth rate of approximately 5–12 metric tonnes per hectare.^{52,53} It is, therefore, considered invasive, as it readily occupies vast areas of land in short periods, and it would prove beneficial to remove it from farmland for use as a raw material in the production of biochar.

Bamboo's growth rate can be attributed to a high rate of photosynthesis, meaning that bamboo absorbs carbon dioxide more quickly than other plants.⁵⁴ Reported values for the amount of carbon dioxide absorbed are 5.1, 12 and 17 tonnes per hectare per year,^{55–57} where the mean value was determined as 11.4 tonnes per hectare per year.

Bamboo has been found to produce more desirable biochar than many other feedstocks. This is due to a greater accumulation of carbon and nitrogen from the initial feedstock in the biochar product, yielding a carbon content of 83.29%.⁴⁹

3.2. Carbon neutrality of bamboo pyrolysis

Although biochar contains a large percentage of fixed carbon from the bamboo feedstock, greenhouse gases are also emitted during pyrolysis, the quantities of which are dependent on the process conditions.

An estimate for the carbon neutrality of the overall process was calculated using available literature data. The biomass of

Table 21 Dry matter accumulation (above ground) of bamboo in different locations of the world (adapted from ref. 56)

Species	Country	Age (years)	Biomass (tonnes ha ⁻¹)
<i>Bambusa bambos</i>	India	4	122
		6	225
		8	287

bamboo per hectare was determined by utilising Table 21, which shows the biomass per hectare of *Bambusa bambos* at different ages.⁵⁶ *Bambusa bambos* is a bamboo species native to India, which has a climate similar to many developing countries.

The relationship between bamboo age and biomass accumulation was assumed to be linear, although it is worth noting that the rate of increase in biomass would likely decline at ages greater than those covered in this study. It is important to note that this relationship was initially characterised as $y = 36.6x - 6.2$. However, as the bamboo biomass at 0 years of age would be exactly 0 tonnes ha⁻¹, the estimated intercept value was disregarded and set to reflect this.

Using this approximate relationship, the biomass of bamboo grown in one year was estimated as shown in eqn (1) below, where y represents the biomass of bamboo (tonnes ha⁻¹) and x represents the age (years).

$$36.6x = 36.6(1) \approx 36.6 \text{ tonnes ha}^{-1} \quad (1)$$

A series of calculations were then carried out to determine the point at which the pyrolysis of bamboo to form biochar is carbon neutral. This would further allow appropriate process conditions to be selected to ensure that the process is carbon negative.

It was assumed that each hectare of bamboo can remove 11.4 tonnes of atmospheric carbon dioxide per year. Using the eqn (2) below, the quantity of carbon dioxide removed per tonne of bamboo each year was estimated.

$$\frac{11.4 \text{ (tonnes of CO}_2 \text{ removed) ha}^{-1} \text{y}^{-1}}{36.6 \text{ (tonnes of bamboo) ha}^{-1}} = 0.311 \text{ (tonnes of CO}_2 \text{ removed) (tonnes of bamboo)}^{-1} \text{y}^{-1} \quad (2)$$

It was estimated that 1 tonne of bamboo can remove 0.311 tonnes of carbon dioxide from the atmosphere each year, equating to 31.1% of the bamboo biomass. Therefore, the process would be considered carbon-neutral if at least 31.1% of the bamboo biomass was converted back into carbon dioxide and released into the atmosphere. A yield greater than this would result in a carbon-negative process.

4. Products

In the pyrolysis of bamboo biomass, three main products are formed: a solid biochar phase and a syngas from which two product phases can be derived. The syngas consists of



condensable organic vapours result which result in the formation of a bio-oil product and a non-condensable gaseous fraction.⁵⁸ As established in Section 2.3, the yields of these products differ depending on the process conditions.

4.1. Biochar

Biochar is a highly porous, lightweight, and stable form of carbon with a lifetime of several hundred years.^{59–61} Biochar plays a key role in improving soil health in agriculture due to its ability to retain water, regulate nitrogen leaching, and improve microbial properties, making it an attractive alternative to standard fertilisers.⁵⁹ Biochar can also be used as a catalyst for industrial applications and as an insulation material because of its low thermal conductivity and ability to absorb water up to 6 times its weight.^{62,63} It is also an attractive option for use in water filtration as its porosity supports the removal of chemical, biological and physical contaminants in an inexpensive manner. The formation of biochar from renewable resources makes it an accessible option for low-income communities.⁶⁴

Increasingly, interest in biochar is growing due to the attractiveness of its stability, which can lock atmospheric carbon contained within the biomass for up to 500 years, hence offering an attractive and affordable route for carbon sequestration if performed optimally.⁶⁵

4.2. Bio-oil

The condensable syngas vapours developed during pyrolysis form a crude bio-oil product when condensed. Bio-oils are derived from the thermal cracking of plant cells and their components; as an inherently unpredictable process, thermal cracking results in a wide range of components observed within crude bio-oil, although the most common components are reportedly water, phenolic-based compounds, and acetic acid.^{32,66} Specifically in the pyrolysis of bamboo, light bio-oil, bamboo vinegar and bamboo tar form distinct components of the bio-oil fraction, with bamboo tar the densest component and light bio-oil the least dense.

Condensation enables the separation of crude bio-oil from syngas, typically achieved by operating multiple condensers in series at temperatures ranging from 90 °C to 140 °C.⁶⁷ To further isolate the crude bio-oil into distinct phases, several techniques exist, as summarised in Table 22.

4.2.1 Bamboo tar. Bamboo tar has a harmful impact when sprayed onto crops and soils.⁷² At 500 °C, a maximum of 31% of the condensable components are classified as bamboo tar.⁷³

Around 21.4% of bamboo tar is made up of polycyclic aromatic hydrocarbons (PAH), which are considered carcinogenic, and hence, minimisation of the production of this component may be desired;⁷⁴ minimisation of the tar yield can be achieved by increasing the moisture content of the feedstock, utilising higher operating temperatures, or increasing the residence time.⁷⁵

4.2.2 Bamboo vinegar. Bamboo vinegar can be used successfully to improve crop productivity, plant health and overall harvest quality.^{76,77} Pyrolygneous acid is the most abundant component within bamboo vinegar, which promotes cell growth by catalysing the growth of several microbes as well as enhancing enzyme activation.⁷⁸ It can also be utilised as a fertiliser, where it has been proven to treble the level of usable phosphoric acid and therefore drastically reduce phosphorus deficiencies in plants.⁷⁹ However, extended usage can result in soil acidification.⁷⁸ The addition of bamboo vinegar and biochar simultaneously to soil delivers increased fertility as the biochar provides rich inorganic nutrients and adsorbs the active acid and phenol components from the bamboo vinegar.⁸⁰

4.2.3 Light bio-oil. The crude light bio-oil requires upgrading to allow the realisation of a high-value product, although even after upgrading, the light bio-oil has a significantly lower heating value than conventional fossil fuels, indicating a lack of suitability as a direct fossil fuel replacement.⁸¹ Commonly, it is upgraded *via* a catalytic process, which acts to reduce thermal instability, corrosivity, and the upper viscosity limit.^{46,82} Post-upgrading is used in sectors such as agriculture, water filtration, and fine chemistry, or further upgrading processes can be applied to support the production of biofuel with a heating value similar to fossil fuels.⁸³

Table 22 Bio-oil separation techniques

Method	Time	Complexity	Information
Slow gravity-settling method ⁶⁸	Very slow (3 months)	Low	Takes place at room temperature. Minimal involvement is required
Fast gravity-settling method ⁶⁸	Fast (\cong 8 hours)	Medium	Heating at 90 °C to reduce storage time. Increased operating and capital costs
Solvent fractionation ^{46,69,70}	Fast	Medium	Use of organic and inorganic solvents for separation. Water-soluble components are separated using water. Lower capital cost than fast gravity-settling. Hazardous due to chemicals involved (such as ethyl acetate)
No separation ⁷¹	n/a	n/a	Reduces capital investment, operating costs, and process complexity



Table 23 Gas separation technologies

Gas	Separation method	Information
Carbon monoxide	Pressure swing adsorption	High-purity carbon monoxide, but the feed can require pre-treatment. ^{85,86}
Carbon dioxide	Scrubbing	Monoethanolamine or ammonia solvent adsorbed by solvent. Heating then separates the carbon dioxide. High pressure and energy intensive. ^{87,88}
Methane	Cryogenic capture	Liquefying carbon dioxide at low temperature. Simple technology but with high energy and cost requirements. ^{89–91}
Hydrogen	Water–gas shift reaction	Fixed bed reactor at 250–350 °C. ⁹²

4.3 Non-condensable gases

In the pyrolysis of bamboo, the non-condensable component of syngas predominantly consists of:⁵⁸

1. Carbon monoxide.
2. Carbon dioxide.
3. Methane.
4. Hydrogen.
5. Oxygen.

The exact composition of the gas stream is dependent on the feed composition and type of pyrolysis employed (and hence the associated conditions) as previously defined.

Due to the presence of combustible components such as methane and hydrogen, the gaseous stream contains a significant quantity of energy. The utilisation of the gaseous streams' stored energy is an attractive offering, with the potential for commercialised external sales or energy integration within the system.

Alternatively, considering the myriad of uses of the gases as individual components, separation may be preferable to bulk combustion. Obtaining a pure hydrogen gas stream may be desired given its negligible GWP impact in comparison to that of carbon dioxide and methane, as well as the societal shift towards a hydrogen economy.⁸⁴ The separation of carbon dioxide from the product stream, followed by the deployment of an appropriate treatment technology, can decrease the overall environmental impact of the process.

Potential separation technologies to isolate each of the respective individual components from the gaseous stream are summarised in Table 23. Consideration of economics is outside of the scope of this review, although it is evidentially an important consideration in the selection of an appropriate separation method and desired end-product.

It is noted that venting of the non-condensable gases is also possible, although non-preferable due to the direct release of methane, which is a greenhouse gas with 25 times the global warming potential (GWP) of carbon dioxide.⁹⁰

5. Biochar production applied to the developing world

Considering the relevance of bamboo pyrolysis and biochar production to developing countries, a holistic image is considered.

Firstly, many tropical soils suffer from poor agricultural productivity due to reduced organic matter and nutrient imbalances; biochar can successfully act as a natural fertiliser to facilitate the regeneration of imbalanced soils by acting as a carbon sink, trapping carbon from agricultural biomass.⁹³ Furthermore, the production of biochar can provide an affordable method of carbon capture, delaying the release of greenhouse gases into the atmosphere. By recognising this carbon sequestration ability, biochar can deliver economic and social benefits to developing countries, as agricultural workers can receive carbon credits for biochar production, yielding additional income.⁹⁴

Therefore, maximising the yield of biochar from pyrolysis is an ideal opportunity for developing countries, as the technology associated with biochar production is relatively cheap, widely applicable, and rapidly scalable.²⁰

5.1. Planboo and Elpitiya Plantations

The work conducted on Elpitiya Plantations, Sri Lanka, highlights both the potential benefits of biomass pyrolysis as well as associated improvement. Working in conjunction with Planboo, a Kon-Tiki kiln was successfully created to pyrolyse invasive bamboo. Biochar produced from this process is currently utilised as fertiliser to improve local soil quality, and the syngas is vented into the atmosphere. Farmers receive carbon credits for their biochar production, with Planboo keen to enhance the sustainability of the system by preventing, or optimising, syngas release. The current intention is to flare the syngas and utilise the resulting heat to dry tea leaves on-site, minimising energy losses as well as the release of the greenhouse gas methane.

5.2 Design options

With sustainability at the core of Planboo's aims, three process design options were devised. Each design iteration is compared for its advantages and disadvantages to determine the most suitable choice for implementation on Elpitiya Plantations. To facilitate sufficient biochar production, it was assumed that each designed system would operate at approximately 300 °C. A 1000 kg per day production rate of biochar is used as a basis for design. A process flow diagram for each design iteration is presented with associated mass and energy balances.

5.2.1. Option 1: vent syngas. The first design option is the most simplistic, involving venting all syngas. This process route





Fig. 7 Option 1 block diagram.

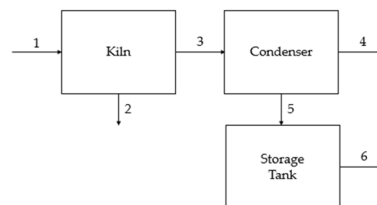

Fig. 9 Option 2 condensation block diagram.

Table 24 Option 1 stream compositions

Component Mass flowrates (kg per day)			
Component	Stream 1	Stream 2	Stream 3
Biomass	2028.40	20.30	
Biochar		1000.00	
CO ₂			365.80
CO			95.30
H ₂			0.70
CH ₄			3.20
VOCs			5.60
H ₂ O			350.50
Others			187.10
Total	2028.40	1020.30	1008.10

produces biochar and unpyrolysed biomass (stream 2) as well as syngas (stream 3). Fig. 7 presents the block diagram for this process and Table 24 contains the mass flow rates in each stream.

5.2.2 Option 2: condense bio-oil for fractionation. The second option presents the possibility of condensing and separating the bio-oil into different fractions. The bio-oil can be condensed from the syngas stream *via* a heat exchanger, which brings cool water or ambient air into contact with the hot syngas stream to allow cooling and subsequent condensation. Slow gravity settling is proposed to separate the condensed bulk bio-oil due to technological simplicity. If no bio-oil separation is desired on-site, it is recommended that a buyer be identified with the capacity and facilities to enable the upgrading of the bulk bio-oil.

As the exact fractional composition of the bio-oil is unknown, no specific mass balance was devised for each of the

separated phases. Although Li *et al.* report a mass spectrometry of similar bio-oil, which is utilised to determine the products obtained from separation, as detailed in Fig. 8.⁹⁵

A process route was devised, incorporating the condensation of bio-oil, as displayed in Fig. 9, with associated stream compositions in Table 25.

5.2.3. Option 3: flare all syngas. A third design option flares all syngas produced in the pyrolysis process (condensable and non-condensable gases) through a venturi burner, producing heat to be utilised elsewhere in the system, such as heating the kiln or drying the tea leaves. A venturi burner is deemed the most appropriate equipment for application in the developing world as it requires no electricity to run and can operate at low pressures.⁹⁶ They are also simple in structure and have minimal maintenance requirements.^{97,98}

Fig. 10 and Table 26 present the detailed schematic and mass balance of this design option.

The energy recovered from this process was calculated and is presented in Table 27.

5.3 Recommended design

The final recommended design combines a retort kiln, a condenser and a venturi burner, a combination of proposed design options 2 and 3. The system is expected to process 2028 kg per day of bamboo to produce 1000 kg per day of biochar, 538 kg per day of bio-oil and approximately 18.41 kW per day of heat from the combustion of 471 kg per day of non-condensable syngas.

The retort kiln will be operated within a temperature range of 250–350 °C, obtaining an approximate biochar yield ranging from 39–65% of the feedstock mass. As discussed in Section 3, this biochar yield is expected to ensure the carbon negativity of the process. The residence time is selected as 8 hours, as this was found to produce biochar containing approximately 59.5% carbon by mass.

The syngas produced from the kiln is fed to a condenser, using water from on-site storage tanks to reduce the temperature to 90 °C, hence condensing the bio-oil. Separated bio-oil can, therefore, be stored and sold for further processing in a variety of industries as appropriate. The remaining syngas is combusted *via* a venturi burner to produce an additional 18.41 kW of energy per day. The integration of produced heat into the kiln system is foreseen to reduce the quantity of firewood required to support the pyrolysis process.



Fig. 8 Carbon chain length distribution in bio-oil.⁹⁵ Reprinted from ref. 95 with permission from [American Chemical Society Publisher], copyright [2020].



Table 25 Option 2 stream compositions

Component mass flowrates (kg per day)						
Component	Stream 1	Stream 2	Stream 3	Stream 4	Stream 5	Stream 6
Biomass	2028.40	20.30				
Biochar		1000.00				
CO ₂			365.80	365.80		
CO			95.30	95.30		
H ₂			0.70	0.70		
CH ₄			3.20	3.20		
VOCs			5.60	5.60		
H ₂ O			350.50		350.50	350.50
Others			187.10		187.10	187.10
Total	2028.40	1020.30	1008.10	470.60	537.50	537.50

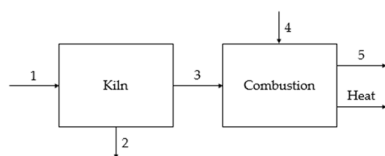

Fig. 10 Option 3 block diagram.

Fig. 11 shows a simple block diagram for this system and Table 28 presents the stream compositions.

The energy balance for this system is presented in Table 29.

6. Limitations and recommendations

Despite the valuable insights offered by this study, several limitations have been identified. The present work solely focuses on bamboo biomass. However, to overcome this, a study should be carried out on other biomass available in the relevant locations and the required comparisons made. Moreover, there are some limitations concerning the complexity of technology due to resources and location. However, this low-complexity technology proves significant in showing that with minimal input, a highly valuable product can be produced (alongside the

Table 26 Option 3 stream compositions

Component Mass flowrates (kg per day)					
Component	Stream 1	Stream 2	Stream 3	Stream 4	Stream 5
Biomass	2028.40	28.30			
Biochar		1000			
CO ₂			365.80		540.70
CO			95.30		
H ₂			0.70		
CH ₄			3.20		
VOCs			5.60		
H ₂ O			350.50		374.20
O ₂				93.90	0
N ₂	0	0	0	353.30	353.30
Other condensable	0	0	187.10	0	187.10
Total	2028.40	1020.30	1008.10	447.30	1445.40

Table 27 Option 3 enthalpy

Component	Mass fraction	Enthalpy of combustion (kJ mol ⁻¹)	Molecular mass (g mol ⁻¹)	Enthalpy of combustion (kJ kg ⁻¹)	Enthalpy (kJ per day)
CO ₂	0.40	0	44.00	0	0
CO	0.10	-283.00	28.00	-10107.10	-962907.50
H ₂	0	-285.80	2.00	-142900.00	-102888.00
CH ₄	0	-891.00	16.00	-55675.00	-177603.30
VOCS (C ₂ H ₄ -C ₃ H ₁₀)	0.01	-1858.70	30.00	-61956.70	-347576.90
H ₂ O	0.40	0	18.00	0	0
Others	0.20	0	100.00	0	0
Total	1	n/a	n/a	n/a	-1590975.70





Fig. 11 Recommended system block diagram.

by-products from syngas) in remote locations of the developing world.

Although bamboo pyrolysis holds significant promise for sustainable biochar production, there are several limitations that need to be addressed to improve its efficiency and practical application.

Process optimisation challenges-the pyrolysis process is highly sensitive to operating conditions such as temperature, heating rate, and residence time, which significantly impact the yield and composition of biochar, bio-oil, and syngas. Achieving optimal conditions requires extensive experimentation and process control.

Energy consumption-the pyrolysis of bamboo requires a substantial energy input, particularly for heating the reactor to the desired temperature range. This can reduce the overall energy efficiency of the process, especially in large-scale operations without energy recovery systems.

Syngas and bio-oil quality-the composition of syngas and bio-oil obtained from bamboo pyrolysis varies widely, often

containing impurities such as tar and acidic compounds. These by-products require further processing and upgrading to be suitable for practical energy applications, increasing operational complexity and costs.

Feedstock variability-the chemical composition and moisture content of bamboo can vary depending on species, growth conditions, and harvest time. This variability can lead to inconsistent pyrolysis performance, affecting product yield and quality.

Environmental and emission concerns-while bamboo pyrolysis aims to reduce greenhouse gas emissions, incomplete combustion or inefficient gas handling can result in the release of CO, NO_x, and other pollutants. Proper emission control measures are essential to minimize environmental impact.

Economic feasibility-the cost-effectiveness of bamboo pyrolysis depends on factors such as feedstock availability, transportation costs, and market demand for biochar and bio-oil. In regions where bamboo is not readily accessible, the economic viability of large-scale operations may be limited.

Limited commercial deployment-although research on bamboo pyrolysis is advancing, large-scale commercial implementation remains limited. The lack of standardised reactor designs, regulatory frameworks, and technological infrastructure poses challenges for widespread adoption.

Addressing these limitations through technological advancements, process optimisation, and policy support can enhance the viability of bamboo pyrolysis as a sustainable biochar production method.

Table 28 Recommended system stream compositions

Component Mass flow rates (kg per day)						
Component	Stream 1	Stream 2	Stream 3	Stream 4	Stream 5	Stream 6
Biomass	2028.40	20.30				
Biochar		1000.00				
CO ₂			365.80	365.80		
CO			95.30	95.30		
H ₂			0.70	0.70		
CH ₄			3.20	3.20		
VOCs			5.60	5.60		
H ₂ O			350.50		350.50	350.50
O ₂						
N ₂						
Others			187.10		187.10	187.10
Total	2028.40	1020.30	1008.10	470.60	537.50	537.50

Table 29 Recommended system enthalpy

Component	Mass (kg per day)	Enthalpy of combustion (kJ mol ⁻¹)	Molecular mass (g mol ⁻¹)	Enthalpy of combustion (kJ kg ⁻¹)	Enthalpy (kJ per day)
CO ₂	365.80	0.00	44.00	0.00	0.00
CO	95.30	-283.00	28.00	-10107.10	-962907.50
H ₂	0.70	-285.80	2.00	-142900.00	-102888.00
CH ₄	3.20	-891.00	16.00	-55675.00	-177603.30
VOCs	5.60	-1858.70	30.00	-61956.70	-347576.90
Total	470.60	N/A	N/A	N/A	-1590975.70



7. Requirement for innovative strategies and procedures to enhance biochar production

The increasing demand for biochar as a sustainable solution for carbon sequestration and soil enhancement calls for the development of innovative strategies and advanced techniques to optimise its production. Achieving higher biochar yield, improved quality, and greater economic feasibility requires a multidisciplinary approach that combines process optimisation, technological advancements, and sustainable resource utilisation. The following key areas highlight opportunities for improvement:

Process optimisation through advanced pyrolysis techniques

- Implementing catalytic pyrolysis to enhance biochar yield while improving the quality of bio-oil and syngas.
- Developing temperature-controlled pyrolysis with real-time monitoring to optimize reaction conditions for maximum carbon retention.
- Exploring microwave-assisted pyrolysis as an energy-efficient alternative to conventional thermal pyrolysis, reducing processing time and energy consumption.

Feedstock pre-treatment and selection

- Introducing pre-drying and torrefaction techniques to reduce feedstock moisture content and improve process efficiency.
- Utilising chemical or biological pre-treatment to modify biomass structure, enhancing biochar yield and stability.
- Investigating the impact of feedstock blending to achieve desired biochar properties, particularly for applications in soil remediation and carbon sequestration.

Integration of energy recovery systems

- Implementing waste heat recovery technologies to improve the overall energy efficiency of pyrolysis reactors.
- Enhancing syngas utilisation by upgrading it for power generation or biofuel production, reducing energy losses.
- Developing closed-loop pyrolysis systems where syngas is used to sustain the pyrolysis process, minimising external energy input.

Reactor design innovations

- Advancing fluidized bed and rotating kiln reactors to improve heat distribution and process scalability.

Developing modular pyrolysis units for decentralised biochar production in rural and industrial applications.

- Exploring hybrid reactor systems that combine slow and fast pyrolysis to maximise biochar yield while co-producing valuable bio-oil.

Sustainable biochar application and product enhancement

- Functionalising biochar through chemical activation to enhance its adsorption capacity for wastewater treatment and soil applications.

• Developing biochar-based composites for industrial applications, such as construction materials and energy storage systems.

- Studying long-term field trials to optimise biochar–soil interactions, ensuring improved crop productivity and carbon sequestration.

Advancing biochar production through the development of new strategies and methodologies is crucial for increasing yield, enhancing product quality, and promoting both environmental and economic sustainability. The integration of innovative pyrolysis technologies, improved reactor designs, and responsible resource management can significantly boost production efficiency. These advancements will strengthen biochar's role in carbon sequestration, renewable energy generation, and soil improvement efforts on a global scale.

8. Summary and outlook

This critical review of the pyrolysis of bamboo biomass demonstrates that there are many key factors to consider throughout the design of a pyrolysis kiln. Many studies indicate the important role of the process conditions, as such parameters appear to influence significantly both the quantity and quality of the products obtained.³³ Therefore, by imposing control over process parameters, pyrolysis operations can, in theory, be tailored and optimised towards a specific goal.

Maximising the yield of biochar is perhaps the most obvious form of pyrolysis optimisation. Scrutiny of available data and studies suggests that this can be done by enforcing relatively low temperatures across relatively short residence times.^{33,42} Furthermore, more specific criteria, such as enhanced biochar carbon content, can be achieved by elevating temperatures and prolonging residence times.⁴³ Highly unique characteristics, such as the specific surface area associated with biochar, can also be increased by amplifying the temperatures and heating rates.^{33,45} The ability to control such specific attributes enables the production of biochar with optimal characteristics for a tremendous range of desired applications, for example, as soil fertilisers or as an effective means of carbon sequestration. Crucially, it is not only the biochar which is influenced by pyrolysis conditions; the yields and compositions of the oil and gas fractions are also greatly dependent upon such parameters. This illustrates how a high degree of optimisation can be achieved through a relatively modest degree of process control.

Aside from process conditions, separation and further treatment of products can also be deployed. Such methods can be applied to the bio-oil and non-condensable gas fractions, enabling the abstraction of valuable components. Such methods vary enormously in terms of complexity and cost, meaning the inclusion of such additional stages is highly limited for applications in developing regions.

Considering each of the factors affecting the efficiency and feasibility of biochar production in developing countries, various potential processes were suggested for implementation. In the case of Elpitya Plantations, simple and inexpensive techniques are desired; therefore, flaring is recommended, with the heat produced being integrated elsewhere within the system or surroundings.⁹⁹ However, as some technology is further developed and becomes more suitable for use in such remote locations, the separation techniques employed will likely be subject to change, further enhancing the environmental benefits.¹⁰⁰



The final recommended design incorporates a retort kiln operating within a temperature range of 250–300 °C, processing approximately 2028 kg per day of bamboo, producing 1000 per day of biochar, resulting in a daily production of 1028 days of bamboo. Moreover, a condenser is incorporated into the design to reduce the syngas temperature to 90 °C, separating approximately 538 kg per day of bio-oil, which can be sold for further processing. Finally, a venturi burner is included to flare any combustible components contained within the gas stream exiting the condenser, producing 18.41 kW per day, as well as approximately 918 kg per day of combustible gases. This system can produce substantial quantities of biochar, which can be applied as a fertiliser or sold for carbon credits. Furthermore, the configuration offers an effective form of process integration, as the heat produced from the venturi burner can be used for the drying of tea leaves on Elpitiya Plantations. However, the most significant capability of this design is the high degree of feasibility for implementation in a developing nation.

The literature highlights that biochar exhibits diverse chemical compositions, surface functionalities, structural characteristics, and morphologies, all of which are influenced by feedstock type and production parameters. This versatility allows biochar to serve not only as an effective adsorbent in environmental applications but also as a potential contributor to rural economic development. Studies involving Techno-Economic Analysis (TEA) and Life Cycle Assessment (LCA) demonstrate that optimising process design and operational parameters can significantly enhance the economic viability of biochar production. Furthermore, biochar's properties can be tailored for specific uses, including the remediation of pollutants from soil, water, and air. Activation techniques—whether physical, chemical, or thermal—further improve its adsorption capacity. However, future research is needed to explore novel activation methods and understand the adsorption/desorption dynamics. Interactions between biochar and microbial communities in the soil also require deeper investigation, especially in relation to nutrient cycling, mineralisation, and pollutant breakdown. Despite its advantages, concerns remain about potential toxic byproducts like polycyclic aromatic hydrocarbons (PAHs) and dioxins from biochar derived from certain biomass sources. The mechanisms behind pollutant removal and its performance in energy storage applications, such as supercapacitors, also need further clarification. Advanced characterisation techniques are essential for fully understanding and optimising biochar's multifunctional properties.

Data availability

The datasets generated during and/or analysed during the current study are available from the corresponding author upon reasonable request.

Author Contributions

Elish Chambers: conceptualization, methodology, introduction, pyrolysis, data curation, visualization, formal analysis,

writing – original draft preparation. Matthew Hassall: conceptualization, use of bamboo as feedstock, data curation, visualization, formal analysis, writing – original draft preparation. Dominic Johnson: conceptualization, product separation, data curation, visualization, formal analysis, writing – original draft preparation. Conall Mcgoran: conceptualization, pyrolysis products, data curation, visualization, formal analysis, writing – original draft preparation. Olivia Williams: conceptualization, product separation, abstract, data curation, visualization, formal analysis, writing – original draft preparation. Aden Blair: conceptualization, formal analysis, visualization, writing – original draft preparation. Freddie Catlow: conceptualization, resources and supervision. Basudeb Saha: conceptualization, writing – review and editing, formal analysis, visualization, resources, supervision and project administration. All authors have read and agreed to the published version of the manuscript.

Conflicts of interest

No conflicts of interest are identified.

Acknowledgements

We would like to thank our supervisor, Dr Saha, for his guidance and encouragement throughout, as well as Planboo for opening our eyes to the potential of biochar. We would like to acknowledge Md Masud Rana Bhuiyan of Lancaster University for his contribution to the design of the journal's back cover for this article.

References

- 1 Y. Chun, S. K. Lee, H. Y. Yoo and S. W. Kim, Recent advancements in biochar production according to feedstock classification, pyrolysis conditions, and applications: A review, *Bioresources*, 2021, **16**(3), 6512–6547.
- 2 European Commission, *Causes of Climate Change*, 2022, https://climate.ec.europa.eu/climate-change/causes-climate-change_en.
- 3 IPCC, *Climate Change 2007: Synthesis Report. Contribution of Working Groups I, II and III to the Fourth Assessment Report of the Intergovernmental Panel on Climate Change*, R. K. Pachauri and A. Reisinger, Geneva, 2007.
- 4 M. Antar, D. Lyu, M. Nazari, A. Shah, X. Zhou and D. L. Smith, Biomass for a sustainable bioeconomy: An overview of world biomass production and utilization, *Renewable Sustainable Energy Rev.*, 2021, **139**, 110691.
- 5 I. Havercroft, *Carbon Capture and Storage: Emerging Legal and Regulatory Issues*, Oxford, Hart Publishing, 2018.
- 6 G. S. Ghodake, S. K. Shinde, A. A. Kadam, R. G. Saratale, G. D. Saratale, M. Kumar, R. R. Palem, H. A. Al-Shwaiman, A. M. Elgorban, A. Syed and D. Kim, Review on biomass feedstocks, pyrolysis mechanism and physicochemical properties of biochar: State-of-the-art framework to speed up vision of circular bioeconomy, *J. Clean. Prod.*, 2021, **297**, 126645.



- 7 Z. E. Zadeh, A. Abdulkhani, O. Aboelazayem and B. Saha, Recent Insights into Lignocellulosic Biomass Pyrolysis: A Critical Review on Pretreatment, Characterisation and Products Upgrading, *Processes*, 2020, **8**, 799.
- 8 D. Patel, S. Kellici and B. Saha, Green process engineering as the key to future processes, *Processes*, 2014, **2**(1), 311–332.
- 9 T. Y. A. Fahmy, Y. Fahmy, F. Mobarak, M. El-Sakhawy and R. E. Abou-Zeid, Biomass pyrolysis: past, present, and future, *Environ. Dev. Sustain.*, 2020, **22**, 17–32.
- 10 M. I. Jahirul, M. G. Rasul, A. A. Chowdhury and N. Ashwath, Biofuels Production through Biomass Pyrolysis —A Technological Review, *Energies*, 2012, **5**(12), 4952–5001.
- 11 N. M. Al-Layla, L. A. Saleh and A. B. Fadhil, Liquid bio-fuels and carbon adsorbents production *via* pyrolysis of non-edible feedstock, *J. Anal. Appl. Pyrolysis*, 2021, **156**, 105088.
- 12 M. Raza and B. Abu-Jdayil, Synergic interactions, kinetic and thermodynamic analyses of date palm seeds and cashew shell waste co-pyrolysis using Coats–Redfern method, *Case Stud. Therm. Eng.*, 2023, **47**, 103118.
- 13 R. K. Mishra, V. Kumar, P. Kumar and K. Mohanty, Hydrothermal liquefaction of biomass for bio-crude production: A review on feedstocks, chemical compositions, operating parameters, reaction kinetics, techno-economic study, and life cycle assessment, *Fuel*, 2022, **316**, 123377.
- 14 R. K. Mishra, D. J. P. Kumar, A. Narula, S. M. Chistie and S. U. Naik, Production and beneficial impact of biochar for environmental application: A review on types of feedstocks, chemical compositions, operating parameters, techno-economic study, and life cycle assessment, *Fuel*, 2023, **343**, 127968.
- 15 D. R. Akwada and E. Akinlabi, Economic, Social and Environmental Assessment of Bamboo for Infrastructure Development, *South Africa: Department of Mechanical Engineering Science*, University of Johannesburg, 2016.
- 16 Planboo, Planboo, <https://planboo.eco/>.
- 17 S. Wang, G. Dai, H. Yang and Z. Luo, Lignocellulosic biomass pyrolysis mechanism: A state-of-the-art review, *Prog. Energy Combust. Sci.*, 2017, **62**, 33–86.
- 18 G. Wang, Y. Dai, H. Yang, Q. Xiong, K. Wang, J. Zhou, Y. Li and S. Wang, A Review of Recent Advances in Biomass Pyrolysis, *Energy Fuels*, 2020, **34**(12), 15557–15578.
- 19 X. Hu and M. Gholizadeh, Biomass pyrolysis: A review of the process development and challenges from initial researches up to the commercialisation stage, *J. Energy Chem.*, 2019, **39**, 109–143.
- 20 M. N. Uddin, K. Techato, J. Taweekun, M. M. Rahman, M. G. Rasul, T. M. I. Mahlia and S. M. Ashrafur, An Overview of Recent Developments in Biomass Pyrolysis Technologies, *Energies*, 2018, **11**(11), 3115.
- 21 A. Sharma, V. Pareek and D. Zhang, Biomass pyrolysis—A review of modelling, process parameters and catalytic studies, *Renewable Sustainable Energy Rev.*, 2015, **50**, 1081–1096.
- 22 J. Liu, X. Chen, W. Chen, M. Xia, Y. Chen, H. Chen, K. Zeng and H. Yang, “Biomass pyrolysis mechanism for carbon-based high-value products, *Proceedings of the Combustion Institute*, pp. 1–25, 2022.
- 23 C. J. Mulligan, L. Strezov and V. Strezov, Technological Advances of Industrial Biomass Pyrolysis, *Pyrolysis: Types, Processes and Industrial Sources and Products*, pp. 237–266, 2009.
- 24 S. Vikram, P. Rosha and S. Kumar, Recent Modeling Approaches to Biomass Pyrolysis: A Review, *Energy Fuels*, 2021, **35**(9), 7406–7433.
- 25 E. Ranzi, A. Cuoci, T. Faravelli, A. Frassolodati, G. Migliavacca, S. Pierucci and S. Sommariva, Chemical Kinetics of Biomass Pyrolysis, *Energy Fuels*, 2008, **22**(6), 4292–4300.
- 26 K. Wang and R. C. Brown, Prospects for Fast Pyrolysis, *Fast Pyrolysis of Biomass: Advances in Science and Technology*, pp. 1–11, 2017.
- 27 W. Cai and R. Liu, Performance of a commercial-scale biomass fast pyrolysis plant for bio-oil production, *Fuel*, 2016, **182**, 677–686.
- 28 A. Oasmaa, J. Lehto, Y. Solantanusta and S. Kallio, Historical Review on VTT Fast Pyrolysis Bio-oil Production and Upgrading, *Energy Fuels*, 2021, **35**(7), 5683–5695.
- 29 M. M. Hasan, M. G. Rasul, M. M. K. Khan, N. Ashwath and M. I. Jahirul, Energy recovery from municipal solid waste using pyrolysis technology: A review on current status and developments, *Renewable Sustainable Energy Rev.*, 2021, **145**, 111073.
- 30 A. Patel, B. Agrawal and B. R. Rawal, Pyrolysis of biomass for efficient extraction of biofuel, *Energy Sources, Part A Recovery, Util. Environ. Eff.*, 2020, **42**(13), 1649–1661.
- 31 L. Ye, J. Zhang, J. Zhao, Z. Luo, S. Tu and Y. Yin, Properties of biochar obtained from pyrolysis of bamboo shoot shell, *J. Anal. Appl. Pyrolysis*, 2015, **114**, 172–178.
- 32 S.-H. Jung, B.-S. Kang and J.-S. Kim, Production of bio-oil from rice straw and bamboo sawdust under various reaction conditions in a fast pyrolysis plant equipped with a fluidized bed and a char separation system, *J. Anal. Appl. Pyrolysis*, 2008, **82**(2), 240–247.
- 33 D. Chen, D. Liu, H. Zhang, Y. Chen and Q. Li, Bamboo pyrolysis using TG–FTIR and a lab-scale reactor: Analysis of pyrolysis behavior, product properties, and carbon and energy yields, *Fuel*, 2015, 79–86.
- 34 T. Brown, M. Wright and R. Brown, Estimating profitability of two biochar production scenarios: slow pyrolysis *vs.* fast pyrolysis, *Biofuel Bioprod. Biorefining*, 2011, **5**, 54–68.
- 35 N. Miranda, I. Motta, R. Filho and M. Maciel, Sugarcane bagasse pyrolysis: A review of operating conditions and products properties, *Renewable Sustainable Energy Rev.*, 2021, **149**, 111394.
- 36 D. Chen, X. Yu, C. Song, X. Pang, J. Huang and Y. Li, Effect of pyrolysis temperature on the chemical oxidation stability of bamboo biochar, *Bioresour. Technol.*, 2016, **218**, 1303–1306.
- 37 P. Parthasarathy, H. Mackey, S. Mariyam, S. Zuhara, T. Al-Ansari and G. McKay, Char Products From Bamboo Waste Pyrolysis and Acid Activation, *Front. Mater.*, 2021, **7**, 624791.



- 38 A. Toptas Tag, G. Duman, S. Ucar and J. Yanik, Effects of feedstock type and pyrolysis temperature on potential applications of biochar, *J. Anal. Appl. Pyrolysis*, 2016, **120**, 200–206.
- 39 A. Demirbas, Effect of Temperature on Pyrolysis Products from Biomass, *Energy Sources*, 2007, **29**, 329–336.
- 40 N. Uddin, W. Daud and H. Abbas, Potential hydrogen and non-condensable gases production from biomass pyrolysis: Insights into the process variables, *Renewable Sustainable Energy Rev.*, 2013, **27**, 204–224.
- 41 G. Newalkar, K. Iisa, A. D'Amico, C. Sievers and P. Agrawal, Effect of Temperature, Pressure, and Residence Time on Pyrolysis of Pine in an Entrained Flow Reactor, *Energy Fuels*, 2014, **28**, 5144–5157.
- 42 A. Sakhiya, P. Baghel, S. Pathak, V. Vijay and P. Kaushal, Effect of Process Parameters on Slow Pyrolysis of Rice Straw: Product Yield and Energy Analysis, in *2020 International Conference and Utility Exhibition on Energy, Environment and Climate Change (ICUE)*, Thailand, 2021.
- 43 J. Sun, F. He, Y. Pan and Z. Zhang, Effects of pyrolysis temperature and residence time on physicochemical properties of different biochar types, *Acta Agric. Scand.*, 2016, 12–22.
- 44 W. Wijayanti and K. Tanoue, Char formation and gas products of woody biomass pyrolysis, *International Conference on Sustainable Energy Engineering and Application*, pp. 145–152, 2013.
- 45 D. Chen, J. Zhou and Q. Zhang, Effects of heating rate on slow pyrolysis behavior, kinetic parameters and products properties of moso bamboo, *Bioresour. Technol.*, 2014, **169**, 313–319.
- 46 D. Mohan, C. U. J. Pittman and P. H. Steele, Pyrolysis of Wood/Biomass for Bio-oil: A Critical Review, *Energy Fuels*, 2006, **20**, 848–889.
- 47 S. Keles, K. Kaygusuz and M. Akgun, Pyrolysis of Woody Biomass for Sustainable Bio-oil, *Energy Sources*, 2011, **33**, 879–889.
- 48 J. Jian, Z. Lu, S. Yao, X. Li and W. Song, Comparative Study on Pyrolysis of Wet and Dry Torrefied Beech Wood and Wheat Straw, *Energy Fuels*, 2019, **33**(4), 3267–3274.
- 49 J. Zhang, F. Lu, C. Luo, L. Shao and P. He, Humidification Characterization of Biochar and its Potential as a Composting Amendment, *J. Environ. Sci.*, 2014, **26**, 390–397.
- 50 B. Lefevre, R. West, P. O'Reilly and D. Taylor, A new method for joining bamboo culms, *Eng. Struct.*, 2019, **190**, 1–8.
- 51 S. Buziquia, P. Lopes, A. Almeida and I. de Almeida, Impacts of bamboo spreading: a review, *Biodiversity Conserv.*, 2019, **28**, 3695–3711.
- 52 E. Cho, Y. Um, S. K. Yoo, H. Lee, H. B. Kim, S. Koh, H. C. Shin and Y. Lee, An Expressed Sequence Tag Analysis for the Fast-Growing Shoots of *Bambusa edulis* Murno, *J. Plant Biol.*, 2011, **54**, 402–408.
- 53 W. Liese and M. Kohl, *Bamboo: the Plant and its Uses*, Illustrated ed., Springer, 2015.
- 54 A. Emamverdian, Y. Ding, F. Ranaei and Z. Ahmad, Application of Bamboo Plants in Nine Aspects, *Sci. World J.*, 2020, **2020**, 1–9.
- 55 M. N. Muchiri and M. O. Muga, A Preliminary Yield Model for Natural *Yushania Alpina* Bamboo in Kenya, *J. Nat. Sci. Res.*, 2013, **3**(10), 77–84.
- 56 K. Seethalakshmi, C. Jijeesh and M. Balagooalan, *Bamboo Plantations: an Approach to Carbon Sequestration*, Thrissur, 2009.
- 57 J. Gan, M. Chen, K. Semple, X. Liu, C. Dai and Q. Tu, Life cycle assessment of bamboo products: Review and harmonization, *Sci. Total Environ.*, 2022, **849**, 157937.
- 58 L. Fiahlo, A. Carnerio, C. Figueiro, M. O. Paula, L. Peres, L. J. Costa and M. Magalhaes, Slow pyrolysis of bamboo: an approach on quality of charcoal and greenhouse gases emission, *Braz. J. Agric. Environ. Sci.*, 2019, **14**, 1–6.
- 59 S. Spears, What is Biochar?: Regeneration International, 2018. <https://regenerationinternational.org/2018/05/16/what-is-biochar/>.
- 60 BiocharLife, BiocharLife - An Impact Venture by Warm Heart Worldwide, 2022. <https://biochar.life/text=BiocharLifeEnvironmentPermitrapidremoval,ofCO2andsequesterfor100years>.
- 61 Ecoshoot, How Eco-friendly Is Bamboo? The Ultimate Bamboo FAQ, 2022, <https://www.ecoshoots.com/bamboo-faq/text=ThereisanFSCcertificationForestStewardshipCouncil,oneis4-6monthsforprocessedbambooproducts>.
- 62 N. Bolan, S. A. Hoang, J. Beiyuan, S. Gupta, D. Hou and A. Karakoti, Multifunctional applications of biochar beyond carbon storage, *Int. Mater. Rev.*, 2022, **67**(2), 150–200.
- 63 S. Usmani, Things You Should Know About the Different Uses of Biochar: BioEnergy Consult, 2021, <https://www.bioenergyconsult.com/applications-of-biochar/text=ThingsYouShouldKnowAbouttheDifferentUses,inwastewatertreatmentE2OurProjectMoreitems>.
- 64 W. Gwenz, N. Chaukura, C. Noubactep and F. N. Mukome, Biochar-based water treatment systems as a potential low-cost and sustainable technology for clean water provision, *J. Environ. Manage.*, 2017, **197**, 732–749.
- 65 J. Yin, L. Zhao, X. Xu, D. Li, H. Qiu and X. Cao, Evaluation of long-term carbon sequestration of biochar in soil with biogeochemical field model, *Sci. Total Environ.*, 2022, **822**, 153576.
- 66 A. Hornung, *Transformation of Biomass: Theory to Practice*, 1 ed., John Wiley & Sons, 2014.
- 67 G. Charis, G. Danha and E. Muzenda, Optimizing Yield and Quality of Bio-Oil: A Comparative Study of *Acacia tortilis* and Pine Dust, *Processes*, 2020, **8**(5), 551.
- 68 R. M. Baldwin and C. J. Feik, Bio-oil Stabilization and Upgrading by Hot Gas Filtration, *Energy Fuels*, 2013, **27**(6), 3224–3238.
- 69 C. Zhao, *Novel Separation Strategy for Processing Biopyrolysis Liquids*, Louisiana State University, 2013.



- 70 Fisher Scientific, *Safety Data Sheet - Ethyl Acetate*, ThermoFisher Scientific, 2020, pp. 1–13.
- 71 G. T. Benz and L. Du, Sourcing Equipment in Developing Countries While Minimizing Risk, 2009, <https://ethanolproducer.com/articles/5831/sourcing-equipment-in-developing-countries-while-minimizing-risk>.
- 72 C. S. Ku and S. P. Mun, Characterization of pyrolysis tar derived from lignocellulosic biomass, *J. Ind. Eng. Chem.*, 2006, **12**(6), 853–861.
- 73 X. Gang, N. Ming-Jiang, H. Huang, C. Yong, X. Rui, Z. Zhao-ping and C. Ke-Fa, Fluidized-bed pyrolysis of waste bamboo, *J. Zhejiang Univ., Sci., A*, 2007, **8**, 1495–1499.
- 74 C. P. Marston, C. Pereira, J. Ferguson, K. Fischer, O. Hedstrom, W.-M. Dashwood and W. M. Baird, Effect of a complex environmental mixture from coal tar containing polycyclic aromatic hydrocarbons (PAH) on the tumour initiation, PAH-DNA binding and metabolic activation of carcinogenic PAH in mouse epidermis, *Carcinogenesis*, 2001, **22**(7), 1077–1086.
- 75 L. P. Rabou, R. W. Zwart, B. J. Vreugdenhil and L. Bos, Tar in Biomass Producer Gas, the energy research centre of The Netherlands (ECN) Experience : An Enduring Challenge, *Energy Fuels*, 2009, **23**(12), 6189–6198.
- 76 M. Zanetti, J. Cazetta, D. de Mattos Junior and S. A. de Carvalho, Influence of pyroligneous extract in spray solution on foliar nutrient content in 'Rangpur' lemon trees, *Rev. Bras. Frutic.*, 2004, 529–533.
- 77 M. Ekebafé, L. Ekebafé and S. Ugbesia, Biochar composts and composites, *Sci. Prog.*, 2015, **98**, 169–176.
- 78 A. Grewal, L. Abbey and L. R. Gunupuru, Production, prospects and potential applications of pyroligneous acid in agriculture, *J. Anal. Appl. Pyrolysis*, 2018, (135), 152–159.
- 79 W. Plaxton and H. Lambers, *Annual Plant Reviews Phosphorous*, Chichester, Wiley Blackwell, 2015.
- 80 X. Luo, Z. Wang, K. Meki, X. Wang, B. Liu, H. Zhneg, X. You and F. Li, Effect of co-application of wood vinegar and biochar on seed germination and seedling growth, *J. Soils Sediments*, 2019, **19**, 3934–3944.
- 81 G. Kabir and B. Hameed, Recent Progress on catalytic pyrolysis of lignocellulosic biomass to high-grade bio-oil and bio-chemicals, *Renew. Sustain. Energy Rev.*, 2017, **70**, 945–967.
- 82 A. Sakka and K. Yoshikawa, Catalytic Upgrading of Bio-oil Produced from Pyrolysis of Rice Husk, in *IOP Conference Series: Earth and Environmental Science*, Thailand, 2018.
- 83 M. Honrubia, Bio oil from biomass: Applications in agriculture, biofuels, and more, <https://www.ennomotive.com/bio-oil-from-biomass/>.
- 84 R. D. Derwent, *Hydrogen for Heating: Atmospheric Impacts*, rdscientific, Newbury, 2018.
- 85 Mayo Clinic, Carbon Monoxide Poisoning, 2022, <https://www.mayoclinic.org/diseases-conditions/carbon-monoxide/symptoms-causes/syc-20370642>.
- 86 T. Tsuji and F. Kasuya, High purity CO gas separation by pressure swing adsorption, *Gas Separation Et Purification*, 1991, **5**, 242–246.
- 87 N. Gilani, *What Are the Uses of Carbon Dioxide Gas?:* Sciencing, 2017, <https://sciencing.com/uses-carbon-dioxide-gas-6364016.html>.
- 88 J. Horton, How CO2 Scrubbing Works, 2022, <https://science.howstuffworks.com/environmental/green-science/carbon-capture.htm>.
- 89 M. Spitoni, M. Pierantozzi, G. Comodi, F. Polonara and A. Arteconi, Theoretical evaluation and optimization of a cryogenic technology for carbon dioxide separation and methane liquefaction from biogas, *J. Nat. Gas Sci. Eng.*, 2019, **62**, 132–143.
- 90 K. U. Leaven, “Separating methane and carbon dioxide to become more efficient,” 2017, <https://biomassmagazine.com/articles/14761/separating-methane-and-carbon-dioxide-to-become-more-efficient>.
- 91 E. Knapik, P. Kosowski and J. Stopa, Cryogenic liquefaction and separation of CO2 using nitrogen removal unit cold energy, *Chem. Eng. Res. Des.*, 2018, **131**, 66–79.
- 92 Woodhead Publishing, Advances in water-gas shift technology: modern catalysts and improved reactor concepts, *Advances in Clean Hydrocarbon Fuel Processing*, pp. 387–412, 2011.
- 93 G. Agegnehu, A. K. Srivastava and M. I. Bird, The role of biochar and biochar-compost in improving soil quality and crop performance: A review, *Appl. Soil Ecol.*, 2017, **119**, 156–170.
- 94 S. K. Das, R. Avasthe, R. Singh and S. Babu, Biochar as carbon negative in carbon credit under changing climate, *Curr. Sci.*, 2014, **107**(7), 1090–1091.
- 95 Y. Li, H. Chen, Y. Wang, Y. Xing, X. Chang, Z. Zheng, Z. Li and X. Zhao, Nitrogen migration mechanism during pyrolysis of penicillin fermentation residue based on the product characteristics and quantum chemical analysis, *ACS Sustain. Chem. Eng.*, 2020, **8**(20), 7721–7740.
- 96 Ward, “Forced Air vs. Venturi Burners: Ward Burner Systems,” 2022, <http://www.wardburner.com/technicalinfo/forcedairvsventuri.html>.
- 97 A. Charles. Hones, Inc., Venturi Burners: Venturi High Pressure Nozzle Burner,” 2019, <https://charlesahones.com/venturi-burners/>.
- 98 A. A. Gallito, R. Zingales, O. R. Battaglia and C. Fazio, An approach to the Venturi effect by historical Instruments, *Phys. Educ.*, 2021, **56**(2), 025007.
- 99 J. Hanania, B. Hefferman, J. Jenden, K. Stenhouse and J. Donev, Flaring: Energy Education, 2018, <https://energyeducation.ca/encyclopedia/Flaring>.
- 100 SEPA, *Guidance on Landfill Gas Flaring*, Environment Agency, Bristol, 2002.

