



Cite this: *Digital Discovery*, 2024, 3, 2032

# Pellet dispensomixer and pellet distributor: open hardware for nanocomposite space exploration via automated material compounding†

Miguel Hernández-del-Valle,<sup>ab</sup> Jorge Ilaraza-Zuazo,<sup>ab</sup> Enrique Dios-Lázaro,<sup>ab</sup> Javier Rubio,<sup>a</sup> Joris Audoux<sup>ac</sup> and Maciej Haranczyk<sup>id</sup>\*<sup>a</sup>

The development of novel polymer-based nanocomposites necessitates the experimental preparation and characterization of numerous compositions to identify optimal formulations. For thermoplastic-based materials, the compounding process typically involves the labor-intensive tasks of dispensing, weighing, mixing, and extruding solid components such as polymers and additives. Herein, we present an open hardware solution that aims to automate this process. Our setup system is designed to streamline material surveying tasks associated with experimental design or closed-loop, self-driving laboratories. Our hardware setup consists of two main components: a multi-material pellet dispenser, which simplifies the preparation of targeted compositions from a range of master batches, and a pellet collector-distributor, which efficiently gathers and distributes processed materials into various containers throughout the experiment.

Received 29th June 2024  
Accepted 21st August 2024

DOI: 10.1039/d4dd00198b

rsc.li/digitaldiscovery

## 1 Introduction

Thermoplastic polymers constitute approximately 75 percent of the plastics market<sup>1</sup> and are widely utilized for their excellent strength-to-weight ratio, high processability, corrosion resistance, and affordability. The properties of these polymers can be further enhanced by incorporating additives such as fibers or nanoparticles. Alternatively, thermoplastic polymers can act as a supporting matrix for various function-bearing particles. Most thermoplastics are currently derived from non-renewable fossil resources and are largely non-biodegradable.<sup>2</sup> However, the development of nature-derived, recyclable, and biodegradable polymeric materials, such as polylactide (PLA) and bionylon-56 (PA56), is gaining traction, finding sustainable applications in industries like automotive and electronics.<sup>3,4</sup>

The development of novel thermoplastic polymers and their composites typically requires extensive testing, involving compounding and subsequent specimen characterization. Plastic compounding is a complex process that involves melt-blending plastics with specific additives to alter various material characteristics, such as thermal and physical properties. This intricate process can include stages like determining additive ratios, high-speed mixing, melt mixing using twin-screw extruders,

cooling, and finally pellet cutting. The pellets is the most common form that thermoplastic polymers, either virgin or compounded, are sold and passed downstream the processing workflow to steps such as injection molding, hot-pressing, or 3D printing.

A representative setup for compounding polymers is presented in Fig. 1, and this example involves a Brabender KETSE 20/40 compounder available in our laboratory. The compounding process starts by introducing the materials to combine into the top hopper of the twin screw extruder. The materials can be in the form of pellets or powder. The twin screw is heated with a precise temperature control system, so in its barrel the materials melt and mix together. They are

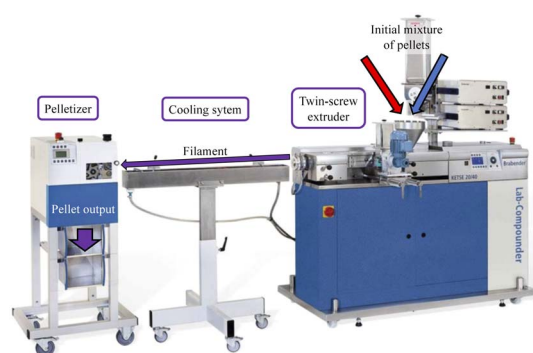

Fig. 1 Polymer extruder workflow illustrated by a Lab-Compounder KETSE 20/40, a water bath and a pelletizer, all of them from Brabender GmbH Co. KG.

<sup>a</sup>IMDEA Materials Institute, c/Eric Kandel, 2, 28906 Getafe, Madrid, Spain. E-mail: maciej.haranczyk@imdea.org; Tel: +34 915 49 34 22

<sup>b</sup>Universidad Carlos III de Madrid, 28911 Leganés, Madrid, Spain

<sup>c</sup>Université de Limoges, 87032 Limoges, France

† Electronic supplementary information (ESI) available. See DOI: <https://doi.org/10.1039/d4dd00198b>



extruded as a hot filament from the hot-end of the extruder. To cool down the filament it is passed through a cooling system, usually a water bath or a conveyor belt with pressured air, depending of the characteristics of the polymer. Once the filament is cooled down and in a solid state, it can be cut into pellets again using a pelletizer.

In this article, we demonstrate open laboratory hardware aiming at automation of the compounding process. In particular, we present: (1) the dispensomixer, which aims to handle the automated material input to the extruder and facilitates changing the material composition during the loading process, and (2) a pellet distributor aimed at the task of the automated collection of the material output from the pelletizer with weight-dependent sorting. Our contribution can facilitate preparation of diverse batches of materials for high-throughput screening studies. Furthermore, it is relevant to the development of Material Acceleration Platforms (MAPs), also known as Self-Driving Laboratories (SDL),<sup>5,6</sup> aimed at thermoplastic-based nanocomposites. Our group has recently demonstrated an SDL for optimization of 3D printing parameters for a given thermoplastic material.<sup>7</sup> The hardware presented here is a key step towards introducing a capability to explore the composition space of such materials.

Our contribution represents a broader trend towards building open and do-it-yourself (DIY) laboratory equipment. The list of reported DIY setups is continuously growing, providing enhanced customization at prices that can be around 94% less than their commercial analogues.<sup>8</sup> The range of application is also incredibly diverse, like recycling of thermoplastic materials,<sup>9</sup> re purposing of household appliances for synthesis of 2D materials,<sup>10</sup> or building low-cost characterization devices as an spectrophotometer<sup>11</sup> or a thermometer,<sup>12</sup> just to cite a few examples. Furthermore, the DIY devices take an important role in the popularization of SDLs. “Frugal twins”<sup>13</sup> refer to low-cost versions of autonomous material laboratories, and a number of successful examples<sup>14–17</sup> have been reported where this kind of setups, heavily-reliant on DIY equipment, can perform closed-loop experiments in a smaller scale and provide crucial information for the development of high-cost autonomous laboratories. Some of its advantages include full-control of the device behavior, ease for parallelization and modularity, at the cost of sacrificing some of the research capabilities of a high-cost platform. When exploring intermediate solutions between a fully-equipped high-cost laboratory and it's frugal, low-cost twin, DIY equipment becomes essential for adapting existing devices to the needs of the automated workflow and find a suitable trade-off between cost and capabilities. Virtually all these highlighted DIY projects share their open-source nature, their reliance in inexpensive production technologies and are a valuable alternative for laboratories all over the world, as well as for citizen science.<sup>18</sup> The DIY trends is capitalizing on democratization of a number of underlying technologies, mainly (i) 3D printing, which has provided an unmatched flexibility and low cost to prototype complex parts in house. Additionally it also backed by a community of makers that share designs and knowledge, allowing a valuable platform for collaboration;<sup>19</sup> (ii) micro-controllers and single-board

computers such as Arduino, Raspberry Pi and others, which again are backed by a strong open-source community that have facilitated the access of non-experts to electronics. They are used at very different complexity levels, from educational tools to professional equipment.<sup>20</sup> The need for material dispensing is common in laboratory practice. In case of liquid materials, there are many both commercial and DIY solutions. In the latter case, for example, there are recent example of pipettes adapted for a collaborative robot use<sup>21</sup> or liquid handlers for preparing different mixtures of reactivities.<sup>22</sup>

Dispensing solid materials is considered a far more challenging task, in part due to the variable particle sizes and shapes and electrostatic interactions between them.<sup>13</sup> M. N. Bahr *et al.*<sup>23</sup> researched on high throughput-automated powder dispensing platforms, all of which rely on gravity to exert a force on the powder, to be then held or released by control systems in which they differ. Examples in this study include Chemspeed FLEX Powderdose, Chemspeed SWING GDU-Pfd and Mettler Toledo CHRONECT Quantos. Generally, the commercial solutions operating at lab scales are expensive and suffer limitations. Researchers find it necessary to look for more suitable alternatives. Y. Jiang *et al.*<sup>24</sup> developed their own system for powder dispensing with the difference that their system is compatible with both powder and pellet dispensing. In this approach, two biomimetic robot arms imitate human dispensing by using the same utensils – namely, a spatula and balance – including corrections for defect and excess dispensing. The downside of this approach is that the mass flow rate is lower than needed for a lab-scale compounding process. Our dispensomixer is specifically designed to work with material in the pellet form and with an output rate compatible with the needs of thermoplastic experimentation (*e.g.* a lab scale-extruder operates at 10 g h<sup>-1</sup> to 1 kg h<sup>-1</sup> range). It consist of eight pellet dispensers with combined outputs allowing for mixing materials from different dispensers. An external balance is also incorporated to monitor the mass flow. Our device was inspired by earlier works in the field of animal feeding, *e.g.* fish feeding.<sup>25</sup> Most of the latter designs rely either in rotors with holes<sup>26,27</sup> or in auger mechanisms.<sup>28</sup> After trying both kinds of designs, the one based on rotors proved a better fit for our case and less prone to obstructions. Nevertheless, it required a substantial prototyping and testing effort to adopt the design to work with hard polymer pellets of various shapes and sizes. The dispensomixer is complemented with the pellet distributor, which to the best of our knowledge does not have a predecessor in our field but obviously devices with the same functionality are widely used in the packaging industry.

## 2 Methods

### 2.1 Pellet dispenser and dispensomixer

**2.1.1 Overview.** A direct inspiration for our dispenser was the Open Source Food Pellet Dispenser,<sup>29</sup> which was adapted to the specific needs of our application as follows. The most relevant design decision was to omit the infrared sensors for detecting and counting the pellets that are dispensed. Our initial investigation has shown that for the amount of pellets



that are needed in each dispensing process, counting pellets using the infrared sensors added an important uncertainty. One part of the uncertainty comes by the irregular size of pellets, specially when they are produced in the lab by cutting extruded polymer filament. By sampling a bag of pellets from the PLA/MMT master batch (later used for the demonstration shown in the Results and discussion section), and assuming a normal distribution, the mean mass of the pellets was 0.009184 grams with a standard deviation of 0.003366 grams. Thus, the relative uncertainty – dependent on the number dispensed – for around 15 000 pellets which conform a mass of 150 grams is:

$$\text{Error} = \frac{\sigma}{\sqrt{N} \cdot \mu} = 0.29\% \quad (1)$$

Considering this relatively small error when sampling large numbers of pellets, which is our case, it might be possible to estimate the dispensed mass by counting the number of pellets and multiplying for their mean mass. However, counting pellets one by one using infrared sensors proved not to be feasible with the kinds of commercial sensors in the price range corresponding to the DIY nature of our setup. The pellets turned out to be too small to be detected, even when the intensity of the emitter was reduced by including resistors.

Instead, we have chosen to use an external balance together with the dispenser to more accurately determine the material amounts and regulate the dispensers accordingly. Other modifications were introduced to facilitate the scaling to parallel eight dispenser setup forming the dispensomixer, *i.e.* changing the Nema17 stepper motors for lighter and more affordable 5 V stepper motors, a redesign of the rotors to adapt them to our pellet sizes and rigidity, or adding ball bearings to the base of the rotors to ensure a smoother rotation under load.

**2.1.2 Design and assembly.** As can be seen in Fig. 2, the dispensomixer design is based on eight dispensing heads arranged around a circular base that holds all the electronics. The pellet material can be stored in the transparent tubes shown in the image. The dispensed pellets fall into a hole in the center of the device and are to be collected in a funnel installed in the dispenser stand.

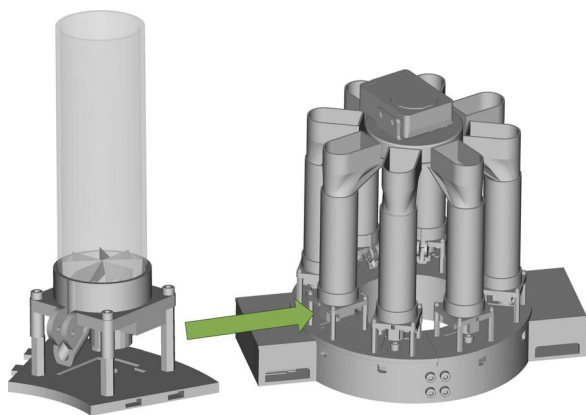

Fig. 2 3D view of the design of a single dispenser head (left) and the full assembly (right), with eight dispenser heads mounted on top of the base and with ionizer on top.

The development of the rotor was an iterative process. Starting from a flat disk with completely circular holes, observations led to the realization that additional relative motion could help release the clusters of pellets which tend to get stuck. For that reason, holes were given a semicircular shape and pushed into the edge of the disk, introducing a moving wall with respect to the disk frame of reference. After noticing that said disk would never totally clear the pellets in the feeder, the next revision featured a ramp leading to each of the holes so that it could be completely emptied out if needed. A last iteration introduces fillets in those surfaces in contact with pellets to smooth out their flow and avoid large clusters blocking the dispensing, which is more likely around sharp edges. Finally, a new version of the code introduced a feature which shakes the rotor to help dissolve the solid clusters of pellets if they were still to form.

To provide customization to the kind of material dispensed, several rotor design are included, so user can select the most adequate one to their pellet size and shape, and to the flow of material required. During the design stage, it became apparent that pellet size and shape affects crucially the dispensing process. In our particular application we mainly dealt with two types of pellets, shown in Fig. 3: the commercially available ones, *e.g.* raw materials, were bigger, with the spheroidal shape of 3–5 mm diameter, while the ones that were extruded and cut in our laboratory were smaller and with a cylindrical shape of around 2–3 mm height, 2–3 mm diameter. To deal with different sizes, the different rotor models provided have different sized holes (5, 7 and 10 mm diameter), and are fast to print and easily exchangeable between experiments, so at any point the models used can be arranged to match the pellet size in each dispenser. The different sizes also allow control over the dispensing speed, as larger holes will mean more material flow but also lower precision, so they should be chosen to balance both.

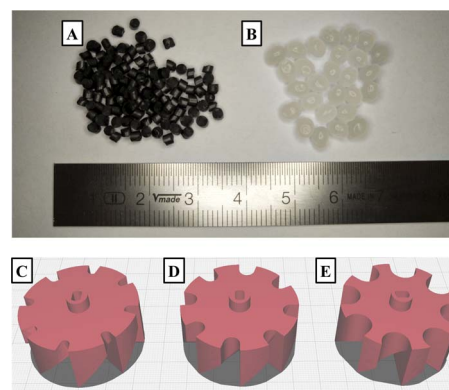

Fig. 3 View of the different pellet sizes and rotor models. Top part of the figure shows two different kinds of pellets: (A), nanocomposite material cut by us after extrusion, with cylindrical shape and smaller size; and (B), commercial PLA pellets, with spherical shape and bigger size. Bottom figure presents the different rotor models. The only difference between them are the sizes of the holes: (C) small (5 mm diameter), (D) large (7 mm), (E) extra large (10 mm). They can be easily exchanged to fit the material that we need to dispense from that particular dispenser head.



The STL files for the 3D printed components of the dispensomixer are available in the Github repository of the project<sup>30</sup> together with the corresponding CAD files in case some modifications are required.

The ESI† file contains a step-by-step guide to assemble all the parts of the device. Fig. 4 presents the final assembly together with accessories such as a stand with a funnel and a balance.

We 3D printed all the components in PLA filament using an Ultimaker UM5 printer. It is advisable to carefully adjust the tolerance using parameters like Horizontal Expansion (available in most slicing softwares) to ensure a proper fit between the different parts.

**2.1.3 Control circuit and software.** For the circuit, we use an Arduino MEGA connected to the computer to run the commands. Each motor is controlled by a A4899 driver that has to be powered externally, as it needs 8 V to work. The schematic for each of the motors is shown in Fig. 5. The sleep pin in the driver is important to avoid overheating of the motor and driver, as well as to reduce consumption of energy when the motors are idle. A Bill of Materials with more detailed description of the components is included in ESI.†

The Arduino code, included in the Github repository of the project,<sup>30</sup> is designed to read serial inputs from the computer defining which motor should be activated at each time. This requires the device to be connected to the control computer while working. The routine for dispensing in each motor includes a combination of movements alternating rotating directions to help prevent blocking and increment the output. The Arduino code is prepared to be integrated with other lab equipment. In an example notebook, also available in the

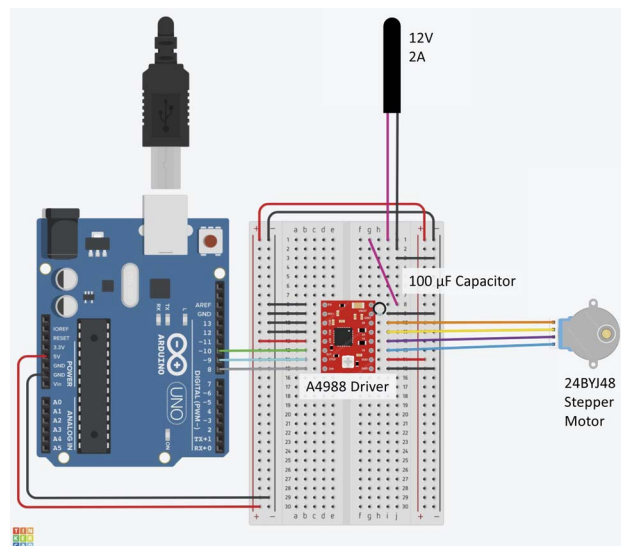

Fig. 5 Circuit for each of the dispensers, to be repeated eight times for the full device. The Arduino UNO showed in the scheme can be substituted by an Arduino MEGA to have more available pins.

repository, the dispensers are integrated with a balance, also connected by serial, to provide precise feedback about the quantity of material dispensed and handle the mixing. This notebook can be easily adapted to the required dispensing required for a number of experiments.

**2.1.4 Cost analysis.** The estimated cost of the dispensomixer is around 250 euros (circa 270 USD), though it can vary depending on the providers, quantities purchased, *etc.* ESI† includes a detailed Bill of Materials summarizing the characteristics, quantities and prizes of the different components.

An important point regarding the cost is the option of adding an air ionizer to prevent static charges collected on pellets during the dispensing. As will be discussed in the Results and discussion Section 3, this can improve the output of the dispenser in the cases where static charges are observed, as was our case. It implies an important increase on the price (the model that we used is listed in ESI† and costs around 571 euros or 600 USD), so it needs to be evaluated for the material of interest and the conditions observed.

## 2.2 Pellet distributor

**2.2.1 Overview.** On the downstream end of our material compounding workflow of Fig. 1, the peletizer is cutting the newly extruded material filament into pellets. Typically, when the process is done manually, the operator has to extract the processed material and prepare it for storage. In our automated setup, we introduce the distributor, a robotized tube arm, able to differentiate the material and direct pellets of different compositions to the corresponding container cups. Our approach is based on the fact that the input material mass flow is determined by the dispensomixer, and therefore output can be also differentiated by mass flow. The pellet distributor uses a balance to monitor the amount of extruded material and changes the collecting container cup from one to another when needed.

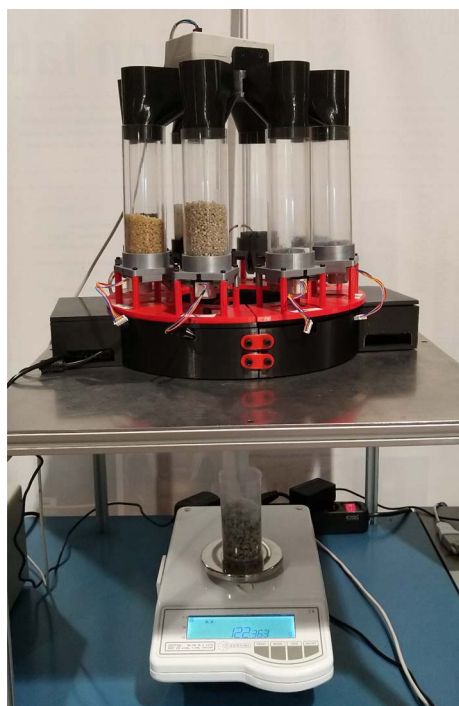

Fig. 4 Fully assembled dispenser placed on top of a table incorporating a funnel that directs the pellets to a plastic cup placed on a balance.



**2.2.2 Design and assembly.** The basic idea for the design is an articulated tube with motors to change positions so it can be placed on top of the cup that is programmed to be filled. This involves designing a top funnel to collect the pellets, several joints to position the arm, and a butterfly valve to open or close the material flow. The design can be seen in Fig. 6, where the arm is shown mounted on the pelletizer and in the intended position to fill the cups in a tray.

All the designs are available as STL files to 3D print in the Github repository of the project,<sup>31</sup> together with the CAD files in case some modifications are required.

The ESI† contains the step-by-step assembly instructions as well as the bill of materials. The 3D printing aspect of the assembly are essentially the same as in the case of dispensomixer. Fig. 7 highlights the final assembly.

**2.2.3 Control circuit and software.** The control system is very similar to the one used for the dispenser, using stepper motors and A4988 drivers connected to an Arduino UNO, that in this case provides more than enough pins, as can be seen in Fig. 8. The only difference is that for the top joint a more powerful motor is needed, as it has to be able to move the whole structure.

The Arduino code is available in the Github repository of the project,<sup>31</sup> as well as a notebook with useful functions to control it. The computer controls the device *via* serial communication. The intended use is together with a balance, so it can receive feedback of when a cup is full and move to fill another. The Arduino code receives control commands to open/close the valve and to move the arm to the desired pose. The paths between poses are determined by the Python code, using the *ikpy*<sup>32</sup> library to compute the rotation of the joints needed for the exit nozzle to reach the desired position *via* Inverse Kinematics calculations.

**2.2.4 Cost analysis.** The estimated price to build the device is around 150 euros (circa 160 USD) based on a Bill of Materials presented in the ESI.† In our case, we decided to pair the pellet



Fig. 7 Final assembly of the pellet distributor, mounted on the pelletizer and filling a tray with several cups on top of a balance for feedback. An air ionizer is mounted at the top of the pellet distributor.

distributor with an electronic balance (285 euros, 300 USD approx.). Furthermore, our initial testing highlighted that it was indispensable to use an air ionizer, as the static charge generated during the filament cooling and cutting was really significant and didn't allow proper function of the device. We used the same one we mentioned in the section regarding the pellet dispenser (2.1.4), and again the need for it in the specific setup needs to be evaluated.

### 2.3 Safety precautions and operational guidelines

In both cases, the devices present minimal risk during assembly and operation. However, several critical considerations must be addressed to ensure safe usage. During assembly, the most sensitive stage is the circuit wiring. It is crucial to conduct the wiring while the circuit is disconnected from all power sources, including external outlets and the PC *via* the Arduino board. Incorrect connections can potentially damage the Arduino

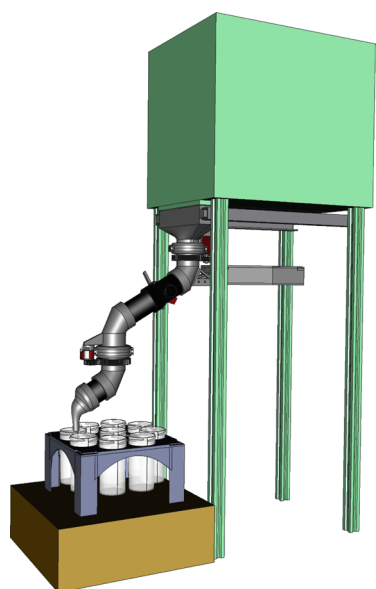

Fig. 6 3D view of the design for the pellet distributor, mounted on a schematic clone of the pelletizer and filling a tray with several cups.

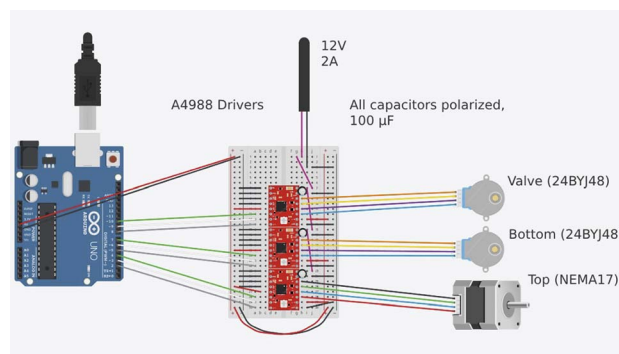

Fig. 8 Circuit to control the joints and valve of the pellet distributor.



board, the PC, or even pose a hazard to the operator. Upon completion of wiring, the circuit should be meticulously reviewed and verified against the schematics provided in Fig. 5 and 8. A critical verification step is ensuring that the ground wire of the 12 V power source is connected to the Arduino board's ground, establishing a common ground for the entire circuit. Connecting the 12 V power source to the breadboard, rather than directly to the Arduino board, mitigates the risk of damage to the Arduino in the event of a short circuit.

After the circuit assembly and wiring, operators can reference the examples available in the GitHub repositories<sup>30,31</sup> to operate the machines and customize the code for various applications. Key safety precautions include refraining from contact with the devices while they are operational to prevent entanglement with moving components, and maintaining an accessible means of disconnecting the 12 V power sources should the devices exhibit any unexpected behavior.

## 3 Results and discussion

### 3.1 Pellet dispenser

**3.1.1 Accuracy tests.** To test and demonstrate the dispensomixer at work, we choose pellets with PLA as the matrix polymer and two 2D clays as additives: Montmorillonite (MMT) and Cloisite (CLO). For both additives we have masterbatches composed of 10% additive and 90% PLA. We set as our objective to fill a 150 g plastic cup with a mixture composed of PLA with 2% MMT and 3% CLO. Thus, we should dispense 30 g of MMT masterbatch, 45 g of CLO masterbatch and the remaining 75 g from pure PLA polymer. The test is summarized in the example notebook described in ESI† and available in the repository.<sup>30</sup>

Instead of directly dispensing said amounts sequentially (although possible), the default behaviour of the program is to alternate between dispensers to ensure that the mixture is more homogeneous, thus eliminating the need for further mixing steps. In every iteration, 1 g of the material that will be present in the smallest amount is dispensed, followed by the proportional amount of the other substances. The balance sends feedback about the amount of material that has been dispensed. When the target amount for the iteration is reached, that dispenser stops and the next one continues. From sending the stop signal until the dispenser stops, a certain amount of pellets keep falling. To reduce this error, that amount of extra pellets are measured and deducted from the next dispensing target. In this way, the error is prevented from accumulating.

The progress of dispensing is highlighted in Fig. 9. Subplot A indicates how much material of each of the compositions is dispensed as a function of time. It can be noted how the materials are being dispensed at the same time to maintain the mixing ratio constant. To better visualize that, we also plot the evolution of ratios in the mixture (subplot B). It can be noted how the ratios have more deviation at the beginning of the process, and this error is reduced progressively. As indicated in the previous paragraph, this is due to the way errors are maintained constant during the experiment, so for larger amounts of material the importance of error is reduced. This indicates that the discussed setup of the dispensomixer is more fit for material amounts

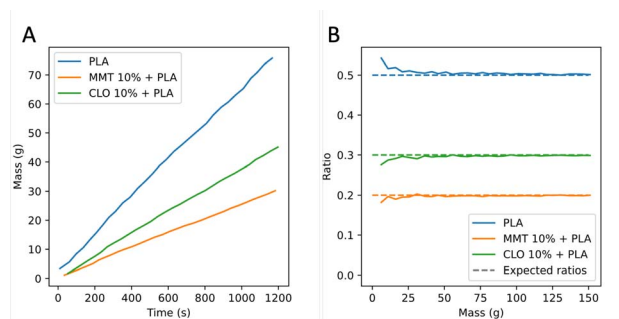

Fig. 9 Example of dispensing process of polymer (PLA) and two masterbatches (PLA+10%MMT and PLA+10%CLO). Subfigure (A) progress of dispensing the three different compositions, calculated to keep the ratios as constant as possible. (B) Ratios of composition of the mixture during the process.

above 50 g approx., although more precision can be obtained by using the rotors with smaller holes at the cost of speed.

The final measured accuracy in this test is of 99.33%, expressed as:

$$1 - \frac{\sum_{i=1}^n |m_i - m'_i|}{\sum_{i=1}^n m_i} \quad (2)$$

where  $m_i$  is the mass of dispensed material for each of the  $n$  materials, and  $m'_i$  is the amount requested for each material.

The mass flow for this experiment was of  $7.59 \text{ g min}^{-1}$  (or  $454.15 \text{ g h}^{-1}$ ).

**3.1.2 Discussion.** As demonstrated in the previous section, the device is able to dispense pellets with satisfactory accuracy at a reasonable speed in the range of material amounts typically used in the lab-scale compounding. In case more material flow is needed, it can be reached by using several dispensing heads for one material, so the output is doubled, tripled, *etc.* This can be specially useful in the cases where one of the materials is more abundant than the rest, as is typically the case for the pure polymer matrix.

The different rotor sizes allows versatility in the shape of pellets to dispense. It is, however, not designed for powders, that have very different aggregation mechanics and can also obstruct the mechanism by infiltrating the joints between moving parts. The upper limit for pellet size is imposed by the size of the holes in the rotors. In the case where some of the dimensions is very close to the diameter of the holes, the flow will be reduced and obstructions will be more frequent. In those cases, it would be necessary to modify the CAD files available in the repository<sup>30</sup> to further customize the device. However, for the most typical sizes in which polymers are commercialized or that can be cut by a pelletizer, our dispenser constitutes a suitable solution to mix up to 8 different materials with an adequate accuracy.

As mentioned in the Cost analysis subsection (2.1.4), a recommendable addition is an air ionizer to get rid of the static charge that is generated by the friction between pellets during the process. In our case, we observed the accumulation of charge and decided to design a part to insert an air ionizer



and distribute the air flow to the deposits. This need is very dependent on the material, the laboratory conditions, *etc.*

### 3.2 Pellet distributor

**3.2.1 Function.** The device operates as follows:

(1) Initial setup: The robotized distributor arm must be positioned straight and perpendicular to the face of the pelletizer. The 9-hole square tray, aligned with the axis of rotation of the bottom joint, is placed on the scale.

(2) Running the Python script: Once the initial setup is complete, the Python script available in the project repository<sup>31</sup> is executed. The scale is automatically tared before the arm begins its operation.

(3) Pellet dispensing process: The arm rotates to the coordinates of the first collecting cup. The valve opens, allowing pellets to flow into the cup. When the predetermined weight capacity of the cup is reached, as measured by the scale, the valve closes. The arm then moves to the next cup.

(4) Sequential filling: This process continues, rotating through all 8 external cups on the tray sequentially, and finally filling the center cup.

(5) Completion: After the center cup is filled, the arm returns to its initial position.

The process, including the method by which the Python script calculates positions using Inverse Kinematics, is illustrated in Fig. 10.

When preparing various compositions in a compounder, the standard practice is to discard the transitional material between compositions due to its uncertain and changing formulation. To manage this, the program includes an option to designate

a slot in the tray as a “Purge position”. This specific slot can be left empty, without a cup, provided that the tray is placed in a larger container to prevent pellets from spilling. Otherwise, the users can also keep the transitional materials if they are a relevant component of their study.

The code also allows flexibility in the filling order. For example, it is possible to fill several cups with the same material if needed, choose when to perform a purge, *etc.*

**3.2.2 Discussion.** In the case of pellet distributor, the problem with static charge turned out to be notorious. Most stages of the material compounding process can induce it: the cooling channel by triboelectric effect due to the air sprayed over the filament; the pelletizer by contact with the rollers or the casing; and even the robot tube itself once the pellets are cut, since they slide over the plastic surface. This causes problems since it causes two negative effects: the pellets tend to get stuck in the tube due to attraction to the walls; and, once a cup reaches a certain fill level, the charged pellets within it act as an electric repellent for oncoming pellets, pushing them away from falling into the cup, and in some instances making them fly out of the cup, as shown in Fig. 11.

The solution of adding an air ionizer was quite effective, as it could be seen instantly how the pellet flow is increased and there is no repulsion in the cups. Again, the need of this addition can depend on the material and specific setup.

The main advantage of our device is the possibility its coupling to other devices in automated workflows such as ones in SDLs. For example, once a tray is full, it can be transported to other stations in the laboratory for sample preparation and characterization. This can be done using autonomous moving platforms, and will be subject of future research from our group. In particular, our tray was designed to fit on a Turtlebot4 robot,<sup>33</sup> a small robotic platform with software for navigation that would be able to transport the prepared compositions to areas where the specimen preparation takes place, *e.g. via* injection moulding or 3d printing.

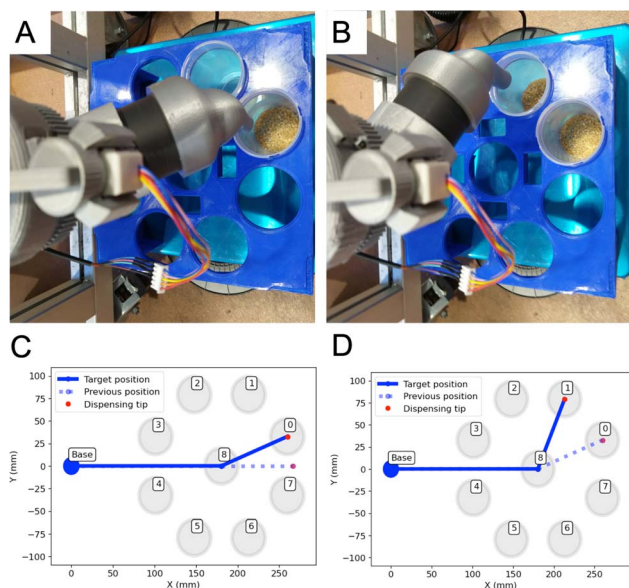

**Fig. 10** Demonstration of the working principle of the pellet distributor. (A) The distributor tip is over a cup number 0. (B) When the required amount of material is detected by the balance, the tip moves to cup 1. (C and D) Represents the Inverse Kinematics calculation of the movement between starting position and cup 0 (C) and between cup 0 and 1 (D). The program calculates the rotation of the joints needed to reach the desired positions.



**Fig. 11** Effect of static electricity in the working of the pellet distributor. Pellets can be seen getting attached to the cup walls and to the tip of the distributor. The aggregation of pellets inside the tube can cause a noticeably reduced throughput.



### 3.3 Evaluation of acceleration factors

Estimating an acceleration factor is complex due to various external factors beyond the device itself. In the corresponding subsection of ESI,<sup>†</sup> we present a comparison of the dispensing rate between the automated dispensomixer and manual dispensing for an example composition, but the estimation is strongly dependent of the composition, amounts of material, dexterity of the manual operator, *etc.*

Instead, in our opinion, the primary advantage lies in the reduction of researchers' time spent on repetitive tasks, allowing them to focus on more intellectually demanding assignments. In the less optimistic scenario, where throughput remains unchanged and automation is limited to the dispensomixer and the distributor, the acceleration is still significant. It reduces the need for two dedicated operators (one for each task) to just one supervisor, who can perform other tasks while remaining available to replace empty material dispensers or conduct other maintenance activities.

The ideal scenario involves further automation through the integration of collaborative robots, enabling an optimal 24/7 continuous workflow, assuming a robust incident control system is in place. In this case, the acceleration factor can exceed four times compared to production limited to standard working hours.

## 4 Conclusions

In this contribution we have described two devices designed to allow automating the compounding of thermoplastic materials. Both are published as open hardware and are based on popular technologies for creation of custom laboratory hardware, *i.e.* 3D printing and Arduino boards.

The first device is a dispensomixer, designed to automatically dispense mixtures of polymers in pellet form with accuracy over 99%. It has capacity to combine up to 8 different materials, making it very versatile for explorations of chemical spaces of high dimensionality. It is customized to handle pellets of different sizes in the ranges in which they are commonly commercialized or manufactured, and its dispensing rate around 0.45 kg h<sup>-1</sup> makes it suitable for lab-scale compounding.

The second device is a pellet distributor that constitutes a convenient way of distributing the produced pellets after cutting the filament at the end of a typical thermoplastic compounding workflow. The new materials can then be easily classified and used in the consequent stages of the experiments. Its Python implementation provides flexibility in the filling sequence (*e.g.* to discard transition materials between compositions) and is convenient for integration in larger workflows.

The low cost and open-source nature of the devices facilitates further customization to a number of different applications and flexibility to implement them in a wide variety of contexts. They can easily be replicated, contributing to the democratization of laboratory equipment. In combination, both instruments represent a notable milestone towards an autonomous laboratory for thermoplastic-based nanocomposite materials.

## Data availability

The CAD files and software related with the project are deposited in two open access Github repositories referenced in the article.

## Author contributions

E. D.-L., J. R. and J. A. developed the dispensomixer. J. I.-Z. developed the pellet distributor. M. HdV. contributed to the software development and testing. M. H. conceptualized and supervised the project. All authors contributed to writing of the manuscript.

## Conflicts of interest

There are no conflicts to declare.

## Acknowledgements

We acknowledge the support from the MAD2D-CM project on two-dimensional disruptive materials funded by the Community of Madrid, the Recovery, Transformation and Resilience Plan, and NextGenerationEU from the European Union.

## Notes and references

- 1 M. Biron, *Material Selection for Thermoplastic Parts*, William Andrew Applied Science Publishers, Chichester, 1st edn, 2016.
- 2 R. Banerjee and S. Ray, *Polym. Eng. Sci.*, 2021, **61**, 617–649.
- 3 J.-M. Raquez, Y. Habibi, M. Murariu and P. Dubois, *Prog. Polym. Sci.*, 2013, **38**, 1504–1542.
- 4 L.-T. Lim, R. Auras and M. Rubino, *Prog. Polym. Sci.*, 2008, **33**, 820–852.
- 5 M. M. Flores-Leonar, L. M. Mejía-Mendoza, A. Aguilar-Granda, B. Sanchez-Lengeling, H. Tribukait, C. Amador-Bedolla and A. Aspuru-Guzik, *Curr. Opin. Green Sustainable Chem.*, 2020, **25**, 100370.
- 6 F. Häse, L. M. Roch and A. Aspuru-Guzik, *Trends Chem.*, 2019, **1**, 282–291.
- 7 M. Hernández-del Valle, C. Schenk, L. Echevarría-Pastrana, B. Ozdemir, E. Dios-Lázaro, J. Ilarraza-Zuazo, D.-Y. Wang and M. Haranczyk, *Digital Discovery*, 2023, **2**, 1969–1979.
- 8 J. M. Pearce, *HardwareX*, 2020, **8**, e00139.
- 9 A. L. Woern, J. R. McCaslin, A. M. Pringle and J. M. Pearce, *HardwareX*, 2018, **4**, e00026.
- 10 D. T. Pérez-Álvarez, J. Brown and J. Stafford, *HardwareX*, 2023, **16**, e00471.
- 11 K. Laganovska, A. Zolotarjovs, M. Vázquez, K. Mc Donnell, J. Liepins, H. Ben-Yoav, V. Karitans and K. Smits, *HardwareX*, 2020, **7**, e00108.
- 12 M. J. Mnati, R. F. Chisab, A. M. Al-Rawi, A. H. Ali and A. Van den Bossche, *HardwareX*, 2021, **9**, e00183.
- 13 S. Lo, S. G. Baird, J. Schrier, B. Blaiszik, N. Carson, I. Foster, A. Aguilar-Granda, S. V. Kalinin, B. Maruyama, M. Politi,



- H. Tran, T. D. Sparks and A. Aspuru-Guzik, *Digital Discovery*, 2024, **3**, 842–868.
- 14 G. S. Ganitano, S. G. Wallace, B. Maruyama and G. L. Peterson, *Prog. Addit. Manuf.*, 2023, 1–11.
- 15 J. Vasquez, H. Twigg-Smith, J. Tran O'Leary and N. Peek, *Proceedings of the 2020 CHI Conference on Human Factors in Computing Systems*, New York, NY, USA, 2020, pp. 1–13.
- 16 D. Salley, G. Keenan, J. Grizou, A. Sharma, S. Martín and L. Cronin, *Nat. Commun.*, 2020, **11**, 2771.
- 17 J. R. Deneault, J. Chang, J. Myung, D. Hooper, A. Armstrong, M. Pitt and B. Maruyama, *MRS Bull.*, 2021, **46**, 566–575.
- 18 J. Feng, B. Khakipoor, J. May, M. Mulford, J. Davis, K. Siman, G. Russell, A. W. Smith and H. King, *HardwareX*, 2021, **10**, e00241.
- 19 A. Silver, *Nature*, 2019, **565**, 123–124.
- 20 H. K. Kondaveeti, N. K. Kumaravelu, S. D. Vanambathina, S. E. Mathe and S. Vappangi, *Comput. Sci. Rev.*, 2021, **40**, 100364.
- 21 N. Yoshikawa, K. Darvish, M. G. Vakili, A. Garg and A. Aspuru-Guzik, *Digital Discovery*, 2023, **2**, 1745–1751.
- 22 R. Keeseey, R. LeSuer and J. Schrier, *HardwareX*, 2022, **12**, e00319.
- 23 M. N. Bahr, M. A. Morris, N. P. Tu and A. Nandkeolyar, *Org. Process Res. Dev.*, 2020, **24**, 2752–2761.
- 24 Y. Jiang, H. Fakhruddin, G. Pizzuto, L. Longley, A. He, T. Dai, R. Clowes, N. Rankin and A. I. Cooper, *Digital Discovery*, 2023, **2**, 1733–1744.
- 25 R. Candelier, A. Bois, S. Tronche, J. Mahieu and A. Mannioui, *Zebrafish*, 2019, **16**, 401–407.
- 26 R. Escobar, B. Gutiérrez and R. Benavides, *Behav. Processes*, 2022, **199**, 104647.
- 27 J. Oh, R. Hofer and W. T. Fitch, *HardwareX*, 2017, **1**, 13–21.
- 28 E. Berglund, *Automatic Fish Feeder De Luxe*, available online, <https://www.thingiverse.com/thing:5517562>, accessed: 2024-06-27.
- 29 J. Kennedy, *et al.*, *Open Source Food Pellet Dispenser*, available online, <https://www.thingiverse.com/thing:1771176>, accessed: 2024-06-27.
- 30 J. Rubio-Romero, J. Audoux, E. Dios-Lázaro and M. H. del Valle, *Pellet\_Dispenser\_Code\_Repository*, available online, <https://github.com/AMDatIMDEA/Pellet-Dispensomixer.git>, accessed: 2024-06-28.
- 31 J. Ilarraza-Zuazo and M. H. del Valle, *Pellet\_Sorter\_Repository*, available online, [https://github.com/AMDatIMDEA/Pellet\\_sorter](https://github.com/AMDatIMDEA/Pellet_sorter), accessed: 2024-06-27.
- 32 P. Manceron, *IKPy*, 2022, DOI: **10.5281/zenodo.6551158**.
- 33 I. Open Source Robotics Foundation, *Turtlebot Website*, available online, <https://www.turtlebot.com/>, accessed: 2024-06-27.

